

ProfiTools Next

Air tools





We are your partner for precise air tools and air motors. Flexibility and customizing according to customer request and requirements are the the outstanding strength. With our professional tools, you benefit from 100 years of experience. With our broad product range you will always get the right tool for your application.

Constant innovations are a cornerstone of our success. Our designers are constantly busy developing new products and improving existing products in order to open up new and mature possibilities for the growing needs of our customers.

You can rely on MANNESMANN DEMAG quality: Our air driven machines have the requirements of industry for many years. Ongoing quality inspections in production, in assembly and final inspection – on in-house test stands – guarantee an optimum for the quality and reliability of the products. The DIN EN ISO 9001:2000 certification confirms our quality system.

Our well-trained and committed employees are our most important asset. Every woman and every man in our team has internalized our high quality standards – in production, administration, external consulting or in the service. So we can always keep our promise to you:

MANNESMANN DEMAG
Partner for the professionals

Contents

Metal processing

Turbine grinding machines	→	6
Grinding machines	→	7
Angle grinding machines (with collet)	→	20
Angle grinding machines	→	22
Radial grinders	→	23
Belt grinders	→	24
Mounted points	→	26
Hose units	→	30
Engraving needle	→	31
Filing machines	→	32
Orbital sanders	→	34

Pneumatic spindles

Pneumatic built-in motors

Spindles	→	40
Non-lubricated turbines	→	42
Built-in air motors	→	43
Built-in air motors with quick drill chuck	→	46
Accessories	→	49

Assembly and torque measuring technology

Impact wrenches	→	70
-----------------	---	----

Drilling and cutting

Drills (pistolgrip)	→	54
Drills (straight)	→	56
Drills (morse taper)	→	58
Angle drills	→	59
Countersinks	→	60
Tapping machines	→	62
Air saw	→	64
Chipping hammers	→	65
Needle scalers	→	66

Accessories

Variacor®-swivel joint	→	74
Filter lubrication units	→	76
Pressure reducers	→	76
Special oil	→	76

Insight in our production	→	77
Air chisel hammers	→	78



Metal processing Professional and reliable



MANNESMANN DEMAG compressed air tools have been meeting industry's requirements for many years. They offer excellent reliability and power. Our products guarantee:

- Precise working under load conditions
- The appropriate compressed air tool for every application, whether it be a
 - grinding or milling machine
 - vertical grinder, belt grinder
 - filing machine, engraving pen, jig saw
 - angle grinding machine
- Safety lever valve (H) according to EN 792
- Alternative model: rotary valve (D)
- Insulating handle
- Exhaust air to rear via hose unit with integrated silencer
- Modular system enables parts to be exchanged if several models are being used
- Absolutely easy to service
- Low air consumption
- Low noise level
- Accessories program for long life, precision and product quality

MANNESMANN DEMAG compressed air tools are ideal partners for grinding, milling, roughing, filing, engraving and cutting-off operations.



→ Robust and powerful – quality products for metal processing by MANNESMANN DEMAG

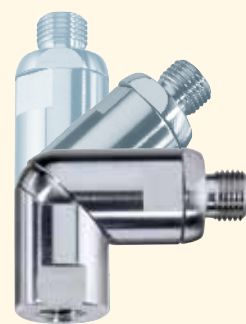

For more flexibility with Variacor® *see page 74*

Oil-free turbine grinding machines

For excellent finishing

65 000 – 100 000 rpm

- High speed for excellent finishing quality
- Easy to service
- High true running accuracy for long term endurance
- Ball bearings with floating support to reduce wear of the rotary burrs
- Non-lubricated use



1



2



3

Technical data

Type		GTV 1000	GT 652 D	GTK 652 D
Article No.		29907-55-5	29940-37-5	29944-57-5
Illustration		2	3	1
Valve		rotary valve	rotary valve	rotary valve
Free speed	rpm	100 000	65 000	65 000
Power	Watt	100	70	70
Exhaust air		to the front	to the rear	to the rear
Discharge brake		—	yes	yes
Spindle front support		flexible	flexible	flexible
Collet included	mm	3	3	3
Carbide rotary burrs max.	mm	3	4	4
Mounted points max.	mm	5	6	6
Noise level	dB(A)	70	65 – 67	65 – 67
Air consumption	l / sec	5.3	3.5	3.5
Weight without hose	kg	0.21	0.27	0.27
Ø machine	mm	30	17	22
Machine length	mm	120	173	135
Hose unit		included	included	included
Supply air hose	m	1.5	1.5	1.5
Exhaust air hose	m	—	1	1
Connection		hose insert nozzle	hose insert nozzle	hose insert nozzle
Accessories supplied		wrench	wrench	wrench

Power and free speed at 6 bar operating pressure. Compressed air quality: oil-free.

Collets



Clamp. range Ø (mm ")	1.0	1.5	2.0	2.5	3.0	1/8"	3/32"
All types	9 369 912	9 369 913	9 369 914	9 369 915	9 369 825	9 369 917	9 369 916

Tool change wrench

To change tools two wrenches are necessary

Article No. (1 piece) 9331037



- Ergonomic design
- Especially for fine milling, grinding, engraving and polishing tasks
- Exhaust air to rear via hose unit with integrated silencer
- Classics among the small grinders
- **G 804 D, G 604 D: elastic spindle support and collet protection cap**

High-speed grinding machines

For light deburring work

55 000 – 80 000 rpm



Technical data

Type		G 813 D	G 813 H	G 804 D	G 604 D	G 551 D	GK 551 D
Article No.		60019-74-5	60019-75-5	60050-33-5	60050-45-5	29939-85-5	29939-86-5
Illustration		1	2	3	3	1	4
Valve		rotary valve	lever valve	rotary valve	rotary valve	rotary valve	rotary valve
Free speed	rpm	70 000	70 000	80 000	60 000	55 000	55 000
Power	Watt	70	70	110	100	100	100
Exhaust air		to the rear	to the rear	to the rear	to the rear	to the rear	to the rear
Collet included	mm	3	3	3	3	3	3
Carbide rotary burrs max.	mm	4	4	4	6	6	6
Mounted points max.	mm	6	6	6	8	8	8
Noise level	dB(A)	76	76	76	74	74	74
Air consumption	l/sec	2	2	3	3	2	2
Weight without hose	kg	0.15	0.18	0.11	0.11	0.15	0.12
Ø machine	mm	14	14	13	13	14	14
Machine length	mm	120	120	113	113	120	100
Hose unit		included	included	included	included	included	included
Supply air hose	m	1.5	1.5	1.5	1.5	1.5	1.5
Exhaust air hose	m	1	1	1	1	1	1
Connection		plug-in socket	plug-in socket	plug-in socket	plug-in socket	plug-in socket	plug-in socket
Accessories supplied		wrench	wrench	wrench	wrench	wrench	wrench

Power and free speed at 6 bar operating pressure. Compressed air quality: lubricated.

Collets



Clamp. range Ø (mm ")	1.0	1.5	2.0	2.5	3.0	1/8"	3/32"
All types	9 369 912	9 369 913	9 369 914	9 369 915	9 369 825	9 369 917	9 369 916

Tool change wrench

To change tools two wrenches are necessary

Article No. (1 piece) 9331037



Grinding machines

With elastic support

25 000 – 38 000 rpm

- Ergonomic design
- Exhaust air to rear via hose unit with integrated silencer
- Safety lever valve according to EN 792
- Powerful vane motor
- reduced carbide burr wear and extended lifetime, less cutting edge breakouts
- elastic support ensures a less shattering work



G 357 H



G 236 H

Technical data

Type		G 357 D	G 357 H	G 236 H
Article No.		60022-74-5	60022-75-5	60020-81-5
Valve		rotary valve	lever valve	lever valve
Free speed	rpm	38 000	38 000	25 000
Power	Watt	290	290	440
Exhaust air		to the rear	to the rear	to the rear
Collet included	mm	6	6	6
Carbide rotary burrs max.	mm	10	10	12
Mounted points max.	mm	16	16	24
Noise level	dB(A)	73	73	76
Air consumption	l/sec	7.5	7.5	12.0
Weight without hose	kg	0.50	0.50	1.00
Ø machine	mm	36	36	46
Machine length	mm	170	170	210
Hose unit		inclusive	inclusive	inclusive
Supply air hose	m	2.5	2.5	2.5
Exhaust air hose	m	1	1	1
Connection thread		G 1/4"	G 1/4"	G 1/4"
Accessories supplied		wrench	wrench	wrench

Power and free speed at 6 bar operating pressure. Compressed air quality: lubricated.

Collets



Clamp. range Ø (mm)	3.0	4.0	5.0	6.0	8.0
G 357 D G 357 H	9 369 841	9 369 846	9 369 847	9 369 826	9 369 843
G 236 H	9 369 985	—	—	9 369 837	9 369 818

- Ergonomic design
- Exhaust air to rear via hose unit with integrated silencer
- Safety lever valve according to EN 792
- Easy to service
- Powerful vane motor

Grinding machines

For light deburring work

35 000 rpm



G 352 D



G 352 H

Technical data

Type		G 352 D	G 352 H
Article No.		29946-06-5	29946-07-5
Valve		rotary valve	lever valve
Free speed	rpm	35 000	35 000
Power	Watt	290	290
Exhaust air		to the rear	to the rear
Collet included	mm	6	6
Carbide rotary burrs max.	mm	10	10
Mounted points max.	mm	16	16
Noise level	dB(A)	73	73
Air consumption	l/sec	7.5	7.5
Weight without hose	kg	0.36	0.36
Ø machine	mm	30	30
Machine length	mm	171	171
Hose unit		inclusive	inclusive
Supply air hose	m	2.5	2.5
Exhaust air hose	m	1	1
Connection thread		G 1/4"	G 1/4"
Accessories supplied		wrench	wrench

Power and free speed at 6 bar operating pressure. Compressed air quality: lubricated.



Collets

Clamp. range Ø (mm)	3.0	4.0	5.0	6.0	8.0	1/4"
All types	9 369 841	9 369 846	9 369 847	9 369 826	9 369 843	9 369 836

Grinding machines

For light deburring work

30 000 rpm

- Ergonomic design
- Exhaust air to rear via hose unit with integrated silencer
- Safety lever valve according to EN 792
- Easy to service
- Powerful vane motor



G 300 D



G 300 H



GK 282 D



GK 282 H

Technical data

Type		G 300 D	G 300 H	GK 282 D	GK 282 H
Article No.		29923-37-5	29923-38-5	29938-01-5	29938-02-5
Valve		rotary valve	lever valve	rotary valve	lever valve
Free speed	rpm	30 000	30 000	30 000	30 000
Power	Watt	220	220	240	240
Exhaust air		to the rear	to the rear	to the rear	to the rear
Collet included	mm	6	6	6	6
Carbide rotary burrs max.	mm	10	10	10	10
Mounted points max.	mm	16	16	16	16
Noise level	dB(A)	70	70	67	67
Air consumption	l/sec	6.9	6.9	6.6	6.6
Weight without hose	kg	0.45	0.45	0.33	0.33
Ø machine	mm	30	30	30	30
Machine length	mm	207	207	141	141
Hose unit		included	included	included	included
Supply air hose	m	2.5	2.5	2.5	2.5
Exhaust air hose	m	1	1	1	1
Connection thread		G 1/4"	G 1/4"	G 1/4"	G 1/4"
Accessories supplied		wrench	wrench	wrench	wrench

Power and free speed at 6 bar operating pressure. Compressed air quality: lubricated.



Collets

Clamp. range Ø (mm)	3,0	6,0
G 300 D/H	9 369 983	9 369 918
GK 282 D/H	9 369 983	9 369 918

Grinding machines

For heavy roughing work

12 000 – 28 000 rpm

Ideal for rough usage

- Highly precise milling, grinding, roughing und deburring
- Exhaust air to rear via hose unit with integrated silencer
- Safety lever valve according to EN 792
- Suitable for two handed use (G 201 H)



G 283 H | G 232 H | G 120 H



G 201 H



GL 120 H

Technical data

Type		G 283 H	G 232 H	G 201 H	G 120 H	GL 120 H
Article No.		29945-68-5	29935-25-5	60000-29-5	60026-69-5	60027-85-5
Valve		lever valve	lever valve	lever valve	lever valve	lever valve
Free speed	rpm	28 000	25 000	22 000	12 000	12 000
Power	Watt	400	440	440	400	400
Exhaust air		to the rear	to the rear	to the rear	to the rear	to the rear
Collet included	mm	6	6	6	6	6
Carbide rotary burrs max.	mm	10	12	12	12	12
Mounted points max.	mm	16	24	32	32	32
Noise level	dB(A)	76	76	74	74	74
Air consumption	l/sec	7.5	12.0	12.0	12.0	12.0
Weight without hose	kg	0.88	0.74	1.10	0.88	1.20
Ø machine	mm	39	39	39	39	39
Machine length	mm	180	180	280	205	291
Hose unit		included	included	included	included	included
Supply air hose	m	2.5	2.5	2.5	2.5	2.5
Exhaust air hose	m	1.5	1.5	1.5	1.5	1.5
Connection thread		G 1/4"	G 1/4"	G 1/4"	G 1/4"	G 1/4"
Accessories supplied		wrench	wrench	wrench	wrench	wrench

Power and free speed at 6 bar operating pressure. Compressed air quality: lubricated.

Collets



Clamp. range Ø (mm)	3.0	6.0	8.0	10.0	1/4"
All types	9 369 985	9 369 837	9 369 818	9 369 817	9 369 987

Grinding machines

For heavy roughing work

12 000 – 22 000 rpm

- Typen G 16 000 H ans G 12 000 H:
Powerful grinders with governor for constant speed
- **GL 20 000 H: elastic spindle support**



G 17000 HV

G 16000 H | G 12000 H

GL 200 H

GL 20000 H

Technical data

Type		GL 200 H	GL 200 HV	G 17000 HV	G 16000 H	G 12000 H	GL 20000 H
Article No.		60000-27-5	60000-28-5	29931-58-5	60018-43-5	60034-20-5	60055-44-5
Valve		lever valve	lever valve	lever valve	lever valve	lever valve	lever valve
Free speed	rpm	22 000	22 000	17 000	16 000	12 000	20 000
Power	Watt	400	400	750	1 000	900	1 000
Exhaust air		to the rear	to the front	to the front	to the rear	to the rear	to the rear
Collet included	mm	6	6	8	6	6	6
Carbide rotary burrs max.	mm	12	12	15	16	16	12
Mounted points max.	mm	20	20	30	35	50	24
Noise level	dB(A)	78	84	88	79	79	79
Luftverbrauch Leer Last	l/sec	12.0	12.0	15.5	13 20	13 20	18.3
Weight without hose	kg	1.20	1.20	1.55	1.14	1.14	1.20
Ø machine	mm	39	39	46	46	46	46
Machine length	mm	382	382	327	236	236	355
Hose unit		included	—	—	included	included	included
Supply air hose	m	2.5	—	—	2.5	2.5	2.5
Exhaust air hose	m	1.5	—	—	1.0	1.0	1.0
Hose I. D.	mm	—	8	10	—	—	—
Connection thread		G 1/4"	G 1/4" i	G 3/8" i	G 3/8"	G 3/8"	G 1/2"
Accessories supplied		wrench	wrench	wrench	wrench	wrench	wrench

Power and free speed at 6 bar operating pressure. Compressed air quality: lubricated.

Collets

Clamp. range Ø (mm ")	3,0	6.0	8.0	10.0	1/4"
GL 200 H HV	9 369 983	9 369 891	—	—	—
G 17000 HV	9 369 985	9 369 837	9 369 818	9 369 817	9 369 987
G 16000 H G 12000 H GL 20000 H	9 369 855	9 369 839	9 369 842	9 369 852	—



for G 16 000 H | G 12 000 H | GL 20 000 H

Multifunctional tools

- Inclusive adapter DIN M10 x 30 to connect to flexible shafts (see page 14: types GLA)
- Inclusive rebuild set to G 16 000 H and G 12 000 H
- Powerful machines with centrifugal governor
- Extensions up to 1000 mm

Grinding machines Multifunctional 12 000 – 16 000 rpm



GL 16000 H | GL 12000 H

Technical data

Type		GL 16000 H	GL 12000 H
Article No.		60018-44-5	60034-21-5
Valve		lever valve	lever valve
Free speed	rpm	16 000	12 000
Power	Watt	1 000	900
Exhaust air		to the rear	to the rear
Collet included	mm	6	6
Carbide rotary burrs max.	mm	16	16
Mounted points max.	mm	35	50
Noise level	dB(A)	79	79
Air consumption free speed / loaded	l / sec	13 20	13 20
Weight without hose	kg	1.94	1.94
Ø machine	mm	46	46
Machine length	mm	475	475
Hose unit		included	included
Supply air hose	m	2.5	2.5
Exhaust air hose	m	1.0	1.0
Connection thread		G 3/8"	G 3/8"
Accessories supplied		wrench	wrench

Power and free speed at 6 bar operating pressure. Compressed air quality: lubricated.

Extensions

Extension (mm)	100	200
Ø shaft 24.5 mm	600 098 15	600 098 45

Further extensions available on request!

Collets

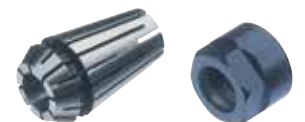

Clamp. range Ø (mm)	6.0	8.0
GL GLA 16000 H	9 369 839	9 369 842
GL GLA 12000 H		
Nut	29701-56-3	29701-56-3

Grinding machines

Variable extension

12 000 – 16 000 rpm



GLA 16000 H | GLA 12000 H

Extension

Technical data

Type		GLA 16000 H	GLA 12000 H
Article No.		60018-45-5	60034-22-5
Valve		lever valve	lever valve
Free speed	rpm	16 000	12 000
Power	Watt	1 000	900
Exhaust air		to the rear	to the rear
Collet included	mm	6	6
Carbide rotary burrs max.	mm	16	16
Mounted points max.	mm	35	50
Noise level	dB(A)	79	79
Air consumption	l / sec	13 20	13 20
free speed / loaded			
Weight without hose	kg	1.25	1.25
Ø machine	mm	46	46
Machine length	mm	256	256
Hose unit		included	included
Supply air hose	m	2.5	2.5
Exhaust air hose	m	1.0	1.0
Connection thread		G 3/8"	G 3/8"
Accessories supplied		wrench	wrench

Power and free speed at 6 bar operating pressure. Compressed air quality: lubricated.

New Product Line!

- Variable extensions in straight or angle version with DIN Adapter M10 × 30 to connect flexible shafts
- Powerful machines with centrifugal governor
- **Free combination of extensions and handpieces**



Handpiece straight, 90°, 45°

Extensions for connection DIN M10 × 30

Extension (mm)	250	500
Ø Shaft 33 mm	60018-93-6	60018-94-6

Handpieces for extensions, Connection G 28

Form		Straight	Angle 90°	Angle 45°
Article No.		60018-92-6	60018-95-6	60018-96-6
Ø × Length	mm	33 × 162	55 × 156	57 × 184
Collet	mm	6	6	6
Weight	kg	0.51	0.81	0.85

Collets

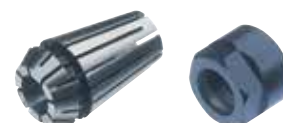

Clamp. range Ø (mm)	6.0	8.0	10.0
Handpiece straight	9 369 935	9 369 936	9 369 937
Handpiece 90°, 45°	9 369 826	—	—

Grinding machines

With extension

10 000 rpm

- Comfortable use by a safety valve embedded into the hand grip
- Ideally for internal grinding, deburring of hollow spaces (e.g. motor blocks, tubes, turbine blades) and for finishing welding lines
- Robust extensions with easy changing
- Max. neck extension length up to 1000 mm ensure working in difficult to access areas
- Spindle with threaded connection M12 for mounted points and carbide burrs
- Built in speed governor keeps the revolutions on load nearly constant



G 100 H

Technical data

Type with collet Ø 6 mm		G 100 H	G 100 H-100	G 100 H-200	G 100 H-400	G 100 H-500
Article No.		60009-35-5	60009-36-5	60009-37-5	60009-38-5	60009-39-5
Type with thread M12		G 101 H	G 101 H-100	G 101 H-200	G 101 H-400	G 101 H-500
Article No.		60009-40-5	60009-41-5	60009-42-5	60009-43-5	60009-44-5
With Extension	mm	—	100	200	400	500
Free speed	rpm	10 000	10 000	10 000	10 000	10 000
Power	Watt	1 300	1 300	1 300	1 300	1 300
Exhaust air		to the side	to the side	to the side	to the side	to the side
Carbide rotary burrs max.	mm	16	16	16	16	16
Mounted points max.	mm	50	50	50	50	50
Flap wheels max.	mm	60	60	60	60	60
Noise level	dB(A)	89	89	89	89	89
Air consumption free speed / loaded	l / sec	11.7 27.7	11.7 27.7	11.7 27.7	11.7 27.7	11.7 27.7
Weight without hose	kg	3.2	3.5	3.8	4.4	4.7
Ø machine	mm	65	65	65	65	65
Machine length G 100 H G 101 H	mm	523 508	623 608	723 708	923 808	1 023 1 008
Air supply hose	m	2.5	2.5	2.5	2.5	2.5
Hose I.D.	mm	13	13	13	13	13
Connection thread		G 1/2"	G 1/2"	G 1/2"	G 1/2"	G 1/2"
Accessories supplied		wrench	wrench	wrench	wrench	wrench

Power and free speed at 6 bar operating pressure. Compressed air quality: lubricated.

Extensions

Extension (mm)	100	200
Ø shaft 24.5 mm	600 098 15	600 098 45

Further extensions available on request!

Collets

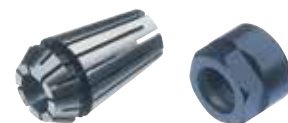

Clamp. range Ø (mm)	6.0	8.0
G 100 H	9 369 839	9 369 842
Nut	29701-56-3	29701-56-3

Grinding machines

Dimensions (mm)

GL 200 H and GL 200 HV

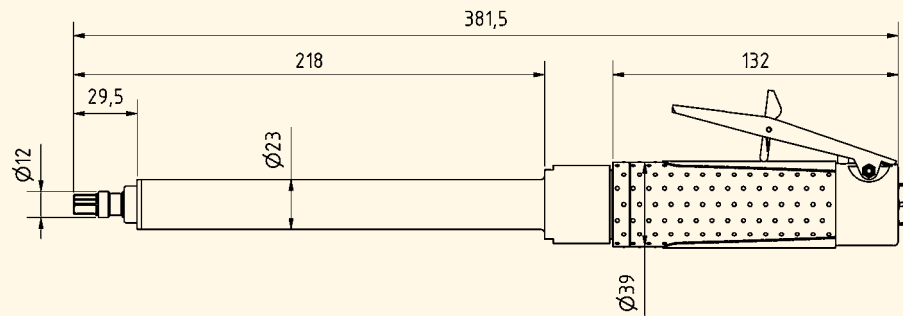

G 16000 H and G 12000 H

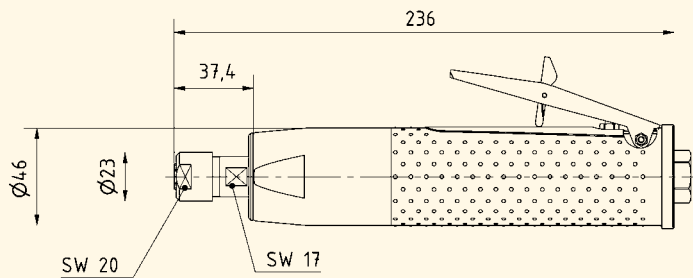

GL 16000 H and GL 12000 H

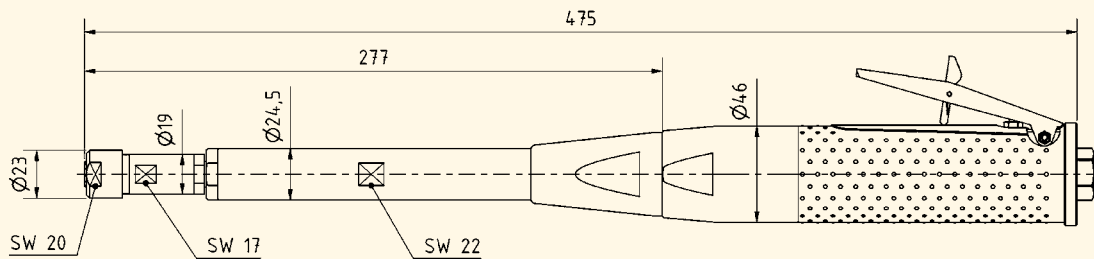

GLA 16000 H and GLA 12000 H

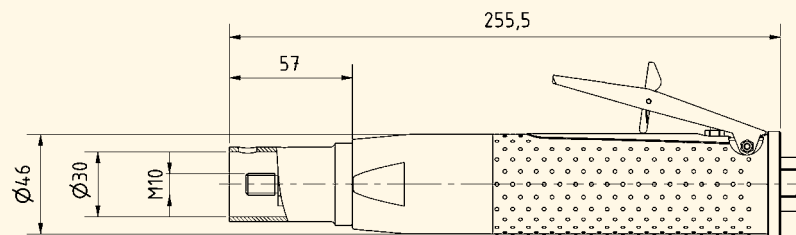

Grinding machines

Dimensions (mm)

G 100 H

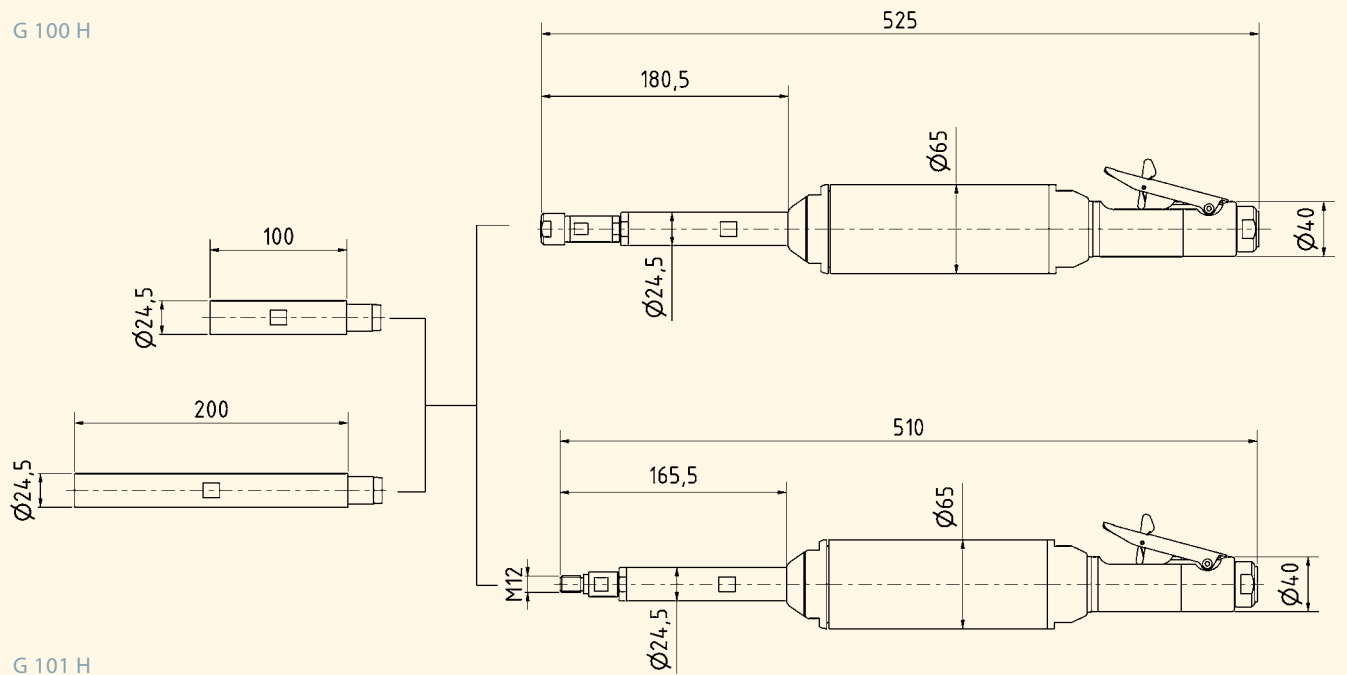

G 101 H

GL 20000 H

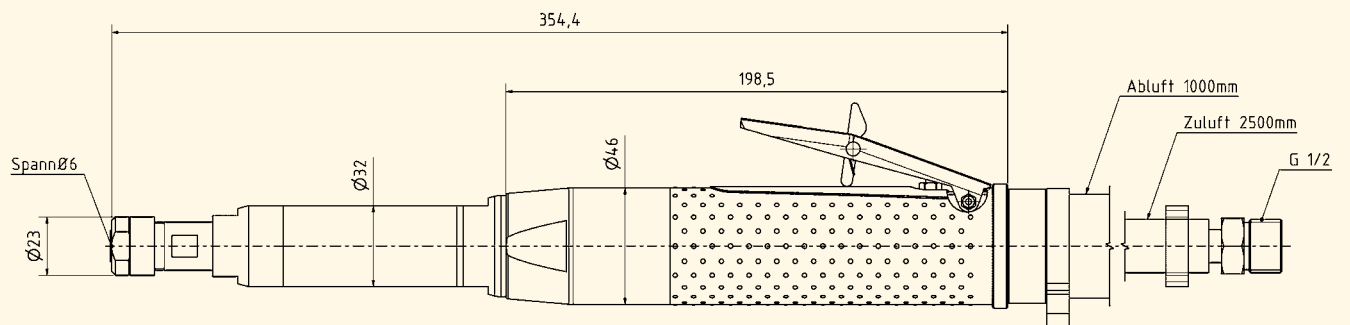

Grinding machines

Exhaust air to the front

30 000 rpm

- Highly precise milling, grinding, roughing und deburring
- High performance and robust
- Safety lever valve according to EN 792
- For light deburring work



GK 282 DV



GK 282 HV



G 281 DV

Technical data

Type		GK 282 DV	GK 282 HV	G 281 DV
Article No.		29938-11-5	29938-12-5	29908-32-5
Valve		rotary valve	lever valve	rotary valve
Free speed	rpm	30 000	30 000	30 000
Power	Watt	240	240	220
Exhaust air		to the front	to the front	to the front
Collet included	mm	6	6	6
Carbide rotary burrs max.	mm	10	10	10
Mounted points max.	mm	16	16	16
Noise level	dB(A)	78	78	79
Air consumption	l/sec	7.5	7.5	5.6
Weight without hose	kg	0.30	0.30	0.41
Ø machine	mm	31	31	30
Machine length	mm	143	143	196
Hose I. D.	mm	8	8	8
Connection		G 1/4" i	G 1/4" i	G 1/4" i
Accessories supplied		wrench	wrench	wrench

Power and free speed at 6 bar operating pressure. Compressed air quality: lubricated.

Collets

Clamp. range Ø (mm)	3.0	6.0
GK 282 DV/HV	9 369 983	9 369 918
G 281 DV	9 369 983	9 369 918



Swivel joint

Variacor	60001-60-6
----------	------------

Further Information see p. 74

- Highly precise milling, grinding, roughing und deburring
- High performance and robust
- Safety lever valve according to EN 792
- G 281 HV for light deburring work
- G 201 HV for two-handed use

Grinding machines

Exhaust air to the front

22 000 – 30 000 rpm



G 281 HV

GK 201 HV

G 201 HV

Technical data

Type		G 281 HV	GK 201 HV	G 201 HV
Article No.		29908-33-5	60001-45-5	60000-30-5
Valve		lever valve	lever valve	lever valve
Free speed	rpm	30 000	22 000	22 000
Power	Watt	220	440	440
Exhaust air		to the front	to the front	to the front
Collet included	mm	6	6	6
Carbide rotary burrs max.	mm	10	12	12
Mounted points max.	mm	16	32	32
Noise level	dB(A)	79	85	84
Air consumption	l/ sec	5.6	12.0	12.0
Weight without hose	kg	0.41	0.95	1.05
Ø machine	mm	30	39	39
Machine length	mm	197	180	280
Hose I.D.	mm	8	8	8
Connection		G 1/4" i	G 1/4" i	G 1/4" i
Accessories supplied		wrench	wrench	wrench

Power and free speed at 6 bar operating pressure. Compressed air quality: lubricated.

Collets

Clamp. range Ø (mm ")	3.0	6.0	8.0	10.0	1/4"
G 281 HV	9 369 983	9 369 918	—	—	—
GK 201 HV and G 201 HV	9 369 985	9 369 837	9 369 818	9 369 817	9 369 987



Swivel joint

Variacor 60001-60-6

Further Information see p. 74

Angle grinding machines

With collet

- For deburring, grinding, milling, polishing and cast cleaning
- GW 218 H/HV with angle head of steel
- Robust finishings, ER-collet
- GW 216 H with angle head of aluminium
- Safety lever valve according to EN 792
- Optimized gear support for a high torque



GW 216 H, GW 126 H



GW 218 H



GW 218 HV

Technical data

Type		GW 216 H	GW 218 H	GW 218 HV	GW 126 H
Article No.		29935-62-5	29934-69-5	29934-82-5	60026-71-5
Valve		lever valve	lever valve	lever valve	lever valve
Free speed	rpm	20 000	20 000	20 000	12 000
Power	Watt	350	350	350	350
Exhaust air		to the rear	to the rear	to the front	to the rear
Collet included	mm	6	6	6	6
Carbide rotary burrs max.	mm	12	12	12	12
Mounted points max.	mm	24	24	24	24
Grinding wheel max.	mm	75	75	75	75
Noise level	dB(A)	74	74	88	74
Air consumption	l/sec	10.0	10.0	10.0	10.0
Weight without hose	kg	1.00	1.15	1.15	1.00
Machine height	mm	67.3	76.0	76.0	68.0
Machine length	mm	150	150	167	174
Hose I.D.	mm	—	—	8	—
Hose unit		included	included		included
Supply air hose	m	2.5	2.5	—	2.5
Exhaust air hose	m	1.5	1.5	—	1.5
Connection		external thread G 1/4"	external thread G 1/4"	internal thread G 1/4"	external thread G 1/4"
Accessories supplied		wrench	wrench	wrench	wrench

Power and free speed at 6 bar operating pressure. Compressed air quality: lubricated.



Collets

Clamp. range Ø (mm)		3.0	6.0	8.0
GW 216 H 126 H	ER 11	9 369 853	9 369 832	—
GW 218 H and HV	ER 16	9 369 855	9 369 839	9 369 842

Angle grinding machines With collet

Combidisc for GW 216 H, GW 218 H, GW 218 HV and GW 126 H

For the professional treatment of surfaces, radii or outlines

A 01	1 holder, \varnothing 50 mm	Article No. 9368 610
A 02	10 grinding discs, \varnothing 50 mm, grain 36	Article No. 9368 614
A 03	10 grinding discs, \varnothing 50 mm, grain 60	Article No. 9368 615
A 04	10 grinding discs, \varnothing 50 mm, grain 120	Article No. 9368 616
B 01	1 holder, \varnothing 50 mm	Article No. 9368 611
B 02	10 grinding discs, \varnothing 50 mm, grain 60	Article No. 9368 612
B 03	10 grinding discs, \varnothing 50 mm, grain 120	Article No. 9368 613



GW 216 H | GW 126 H dimensions (mm)

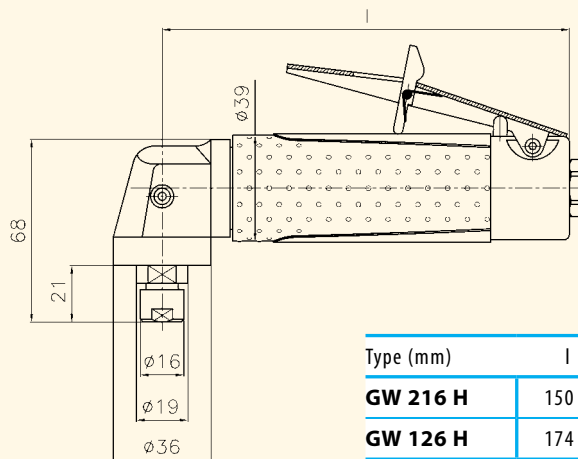

GW 218 HV | GW 218 H dimensions (mm)

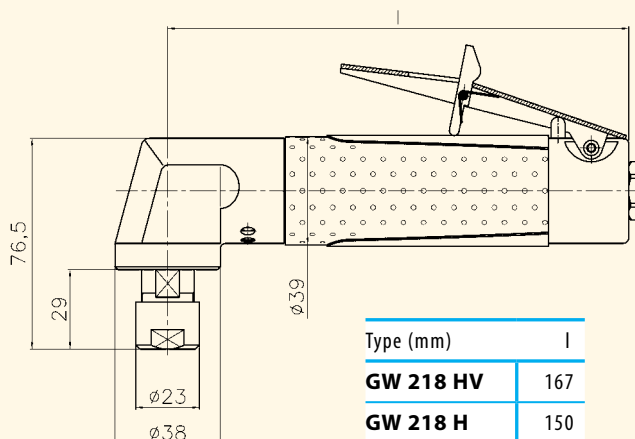

Angle grinding machines

Roughing, grinding and polishing

For fibre-reinforced grinding discs or for use with elastic rubber discs



MDWS 4200



GW 121 H

- Type MDWS 4200:
 - integrated governor, spindle stop
 - Protection hood 360° adjustable
 - Safety lever valve according to EN 792
- Type GW 121 H:
 - with centrifugal governor, automatic out-of-balance compensation
 - Low angle head height
 - Dust extraction system upon request

Technical data

Type		MDWS 4 200	GW 121 H
Article No.		82600-10-3	60012-07-5
Illustration		1	2
Valve		lever valve	lever valve
Free speed	rpm	12 000	12 000
Power	Watt	1 100	1 100
Exhaust air		to the rear	to the rear
Spindle thread		M 14	M 14
Grinding wheel max.	mm	125	125
Noise level	dB(A)	90	83
Air consumption	l / sec	19.9	15.0
Weight without hose	kg	1.60	2.10
Machine height	mm	88	98
Machine length	mm	220	240
Hose I. D.	mm	13	13
Hose unit		included	included
Supply air hose	m	1.5	2.5
Exhaust air hose	m	0.8	1.0
Connection		G 3/8"	G 1/2"
Accessories supplied		wrench, side handle	wrench, side handle

Power and free speed at 6 bar operating pressure. Compressed air quality: lubricated.



Accessories

For Type		MDWS 4 200	GW 121 H
Hose unit		—	60012-09-5
Rubber plate		9 368 202	9 368 231
Fibre	Grain 36	9 368 009	9 368 237
	Grain 60	9 368 224	9 368 238
	Grain 80	9 368 010	9 368 239

Hose unit: incl. supply / exhaust air hose.

- Robust and powerful
- Non- lubrication and low maintenance use
- Security chucking
- Speed governor

Radial grinders

For the use of grinding wheels



R

Technical data

Type		R 12125	R 10125
Article No.		60022-88-6	60022-87-6
Valve		lever valve	lever valve
Free speed	rpm	12 000	10 000
Power	Watt	3 100	3 000
Exhaust air		to side	to side
Spindle thread	mm	5/8 " × 55	5/8 " × 55
Grinding wheel (only bolstered)	mm	125 × 20 × 25	125 × 20 × 25
Noise level	dB(A)	88	86
Vibration	m / s ²	4.5	4.2
Air consumption free speed / loaded	l / sec	18 / 50	18 / 48
Weight	kg	2.9	2.9
Machine length	mm	467	467
Hose I. D.	mm	16	16
Connection		G 1/2"	G 1/2"
Accessories supplied		With adapter-hole 25 × 20 and 25 × 25 mm, wrench for tool changing, nut and flanges, protective cap	

Power and free speed at 6 bar operating pressure. Compressed air quality: lubricated.

Accessories

Adapter STR 22 × 20	5/8 " spindle	60028-75-6
Adapter STR 20 × 25	5/8 " spindle	60028-76-6
Adapter STR 25 × 25	5/8 " spindle	60028-77-6

Belt grinders

For belt length 330 and 610 mm



GB 14 000

GB 14000

- For sanding with or without belt support contact
- With belt cooling
- For belt width 6 mm and 13 mm
- Belt arm replacements available as accessories

GB 815 H

- Sanding arm included
- Powerful motor
- Easy change of belts
- Air exhaust integrated in included air supply hose
- Compact design, small weight
- Telescopic belt tension
- Suitable for sanding belts 8 and 15 mm

Technical data

Type		GB 14000	GB 815 H
Article No.		60011-25-6	60010-68-5
Free speed	rpm	20 000	20 000
Power	Watt	400	350
Exhaust air		to the rear	to the rear
Belt measures	mm	610×6 / 610×13	330×8 / 330×15
Belt run speed	m / s	20	20
Noise level	dB(A)	73	76
Air consumption	l / sec	14.1	10.0
Weight without hose	kg	1.40	0.95
Machine height	mm	116	38
Machine length	mm	371	295
Hose I. D.	mm	8	—
Hose unit		—	included
Supply air hose	m	—	2.5
Exhaust air hose	m	—	1.5
Connection		G 1/4"	G 1/4"
Accessories supplied		contact arm 11218	sanding arm

Power and free speed at 6 bar operating pressure. Compressed air quality: lubricated.



GB 815 H

Belt grinders

Contact arms and abrasive belts



Contact arm A



Contact arm B



Contact arm C



Contact arm D



Contact arm E

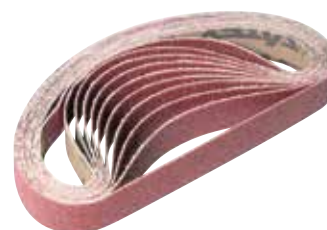

Abrasive belts

Contact arms for GB 14 000 (mm)

A	11216	Rubber wheel	Ø 16 × 3	L 610 × B 6	Article No. 60011-26-6
B	11219	Rubber wheel	Ø 25 × 9.5	L 610 × B 6	Article No. 60011-27-6
C	11213	Steel wheel	Ø 8 × 9.5	L 610 × B 13	Article No. 60011-28-6
D	11218	Rubber wheel	Ø 16 × 9.5	L 610 × B 13	Article No. 60011-29-6
E	11231	Rubber wheel	Ø 19 × 13	L 610 × B 13	Article No. 60011-30-6

Abrasive belts (10 pieces)

Korn	60	120	180	240
330 × 8 mm	9368 701	9368 702	9368 703	9368 704
330 × 15 mm	9368 711	9368 712	9368 713	9368 714
610 × 6 mm	9368 725	9368 726	9368 727	9368 728
610 × 13 mm	9368 729	9368 730	9368 731	9368 732

Carbide rotary burrs

Precision for maximum performance

Optimum chip flow

Toothing 6 Cross cut

- For hardened steels and materials
- High firmness
- Small splinters



Toothing 6

Toothing 5 Fine cut

- For hardened steels up to 65 HRC to the achievement of fine surfaces



Toothing 5

Toothing 1 Alu cut

- For aluminium alloys, yield non-ferrous metals and plastics
- Large swarf spaces



Toothing 1

Material employment refer.

Toothing	1	5	6
Aluminium	x		
Brass, copper, bronze			x
Glass fiber			x
Cast iron			x
Plastic	x		
Steel > 55 HRC		x	x
Steel > 60 HRC		x	x
Steel			x
Stainless steel		x	x
Nickel alloys			x
Welded parts			x
Titanium		x	x
Zinc	x		

Speed recommendation

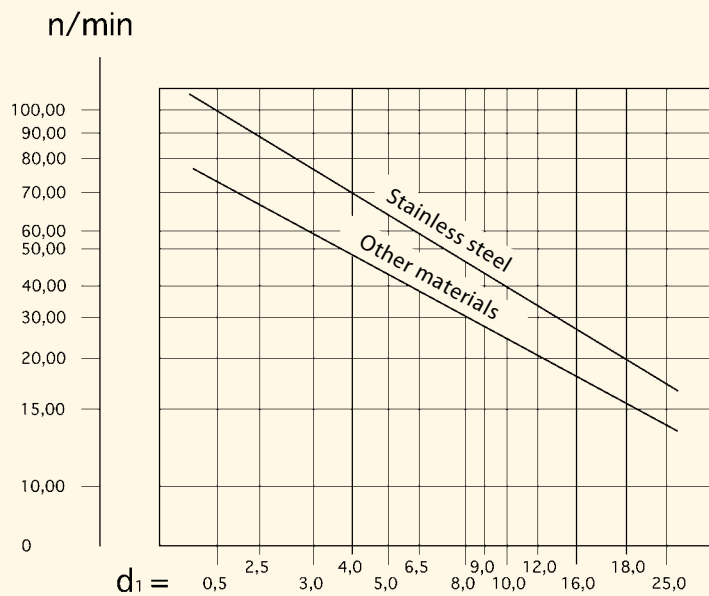

Set of carbide rotary burrs (4 parts and 10 parts)

- Different forms in metal cassette



- ∅ shank 3 mm | ∅ head 3 mm toothing 6 | Article No. 9 376 827
- ∅ shank 6 mm | ∅ head 6/8 mm toothing 6 | Article No. 9 376 826

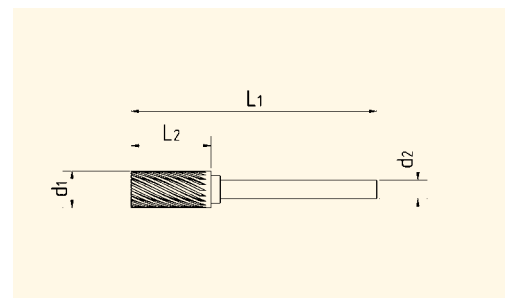

Cylinder (ZYA)

Head ∅ mm d1	Head length mm L2	Shank ∅ mm d2	Length total mm	Article No. toothing 6	Article No. toothing 5	Article No. toothing 1
Shank 3 mm						
2.5	11	3	38	9 376 800	—	—
3	14	3	38	9 376 801	9 376 703	—
6.3	12.7	3	50	9 376 802	9 376 705	—
Shank 6 mm						
6	16	6	50	9 376 831	9 376 707	—
8	19	6	63	9 376 832	9 376 709	—
9.5	19	6	63	9 376 833	9 376 711	9 376 712
12.7	25	6	69	9 376 834	9 376 713	9 376 890

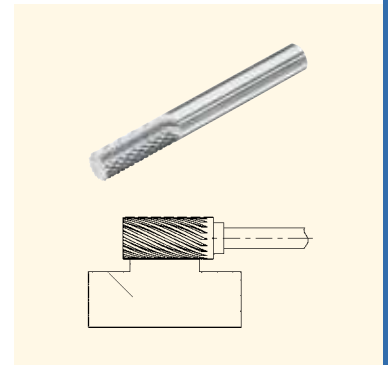

Cylinder (ZYA) with front toothing

Head ∅ mm d1	Head length mm L2	Shank ∅ mm d2	Length total mm	Article No. toothing 6	Article No. toothing 5	Article No. toothing 1
Shank 3 mm						
3	14	3	38	9 376 820	9 376 721	—
Shank 6 mm						
9.5	19	6	63	9 376 725	9 376 726	9 376 727
12.7	25	6	69	9 376 728	9 376 729	9 376 730

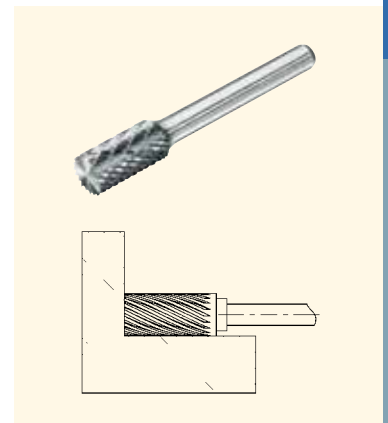

Cylinder (WRC) with radius end

Head ∅ mm d1	Head length mm L2	Shank ∅ mm d2	Length total mm	Article No. toothing 6	Article No. toothing 5	Article No. toothing 1
Shank 3 mm						
3	14	3	38	9 376 803	9 376 741	—
6.3	12.7	3	50	9 376 804	9 376 743	—
Shank 6 mm						
6	16	6	50	9 376 835	9 376 745	—
8	19	6	63	9 376 836	9 376 747	—
9.5	19	6	63	9 376 837	9 376 749	9 376 750
12	25	6	65	9 376 838	9 376 751	9 376 752

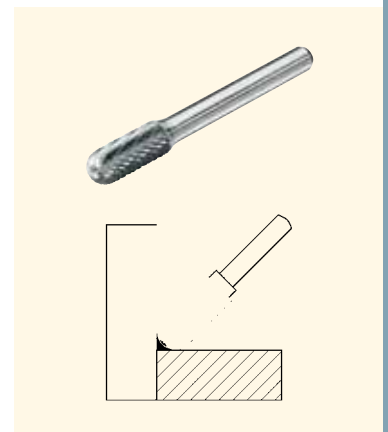

Carbide rotary burrs

KUD, TRE, flame

Ball shape (KUD)

Head Ø mm d1	Head length mm L2	Shank Ø mm d2	Length total mm	Article No. toothing 6	Article No. toothing 5	Article No. toothing 1
Schaft 3 mm						
3	2.5	3	38	9 376 805	9 376 781	—
4	3.4	3	38	9 376 806	9 376 783	—
6	5.4	3	37	9 376 807	9 376 785	—
Schaft 6 mm						
6	6	6	50	9 376 839	9 376 787	—
8	6.4	6	50	9 376 840	9 376 789	—
9.5	8	6	52	9 376 841	9 376 791	—
12	10.8	6	52	9 376 842	9 376 793	9 376 892

Oval shape (TRE)

Head Ø mm d1	Head length mm L2	Shank Ø mm d2	Length total mm	Article No. toothing 6	Article No. toothing 5	Article No. toothing 1
Shank 3 mm						
3	5.5	3	38	9 376 808	9 376 794	—
6.5	9.5	3	47	9 376 809	9 376 796	—
Shank 6 mm						
6	9.5	6	50	9 376 843	9 376 798	—
9.5	16	6	60	9 376 844	9 376 863	—
12.7	22	6	66	9 376 845	9 376 865	—
16	25	6	69	9 376 860	9 376 867	—

Flame shape

Head Ø mm d1	Head Länge mm L2	Shank Ø mm d2	Length total mm	Article No. toothing 6	Article No. toothing 5	Article No. toothing 1
Shank 3 mm						
3	6.3	3	38	9 376 810	9 376 869	—
5	9.5	3	38	9 376 811	9 376 872	—
Shank 6 mm						
8	19	6	63	9 376 847	9 376 882	—
12.7	32	6	76	9 376 849	9 376 887	—

Tree shape (RBF)

Head ∅ mm d1	Head length L2	Shank ∅ mm d2	Length total mm	Article No. toothing 6	Article No. toothing 5	Article No. toothing 1
Shank 3 mm						
3	12.7	3	38	9 376 812	9 376 755	—
6.3	12.7	3	50	9 376 813	9 376 757	—
Shank 6 mm						
6.0	16	6	50	9 376 850	9 376 759	—
9.5	19	6	63	9 376 851	9 376 761	9 376 762
12.7	25	6	69	9 376 852	9 376 763	9 376 894

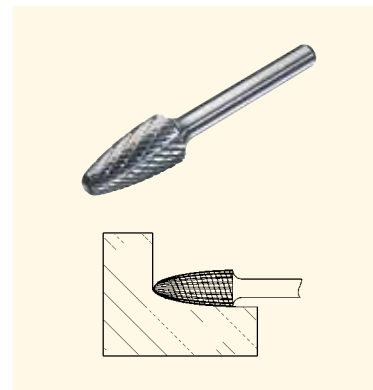

Tree shape pointed end (SPG)

Head ∅ mm d1	Head length mm L2	Shank ∅ mm d2	Length total mm	Article No. toothing 6	Article No. toothing 5	Article No. toothing 1
Shank 3 mm						
3.0	12.7	3	38	9 376 814	9 376 764	—
6.3	12.7	3	50	9 376 819	9 376 815	—
Shank 6 mm						
6.0	16	6	50	9 376 853	9 376 767	—
8.0	19	6	63	9 376 854	9 376 897	—
10.0	20	6	60	9 376 855	9 376 769	—
12.7	25	6	69	9 376 856	9 376 771	9 376 895

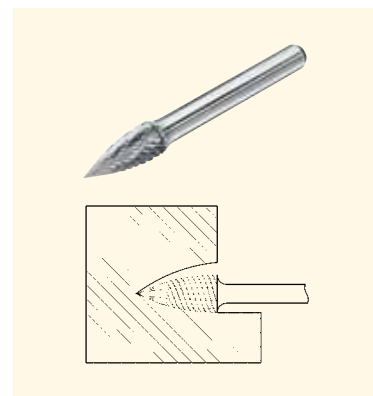

Cone shape (SKM)

Head ∅ mm d1	Head Länge mm L2	Shank ∅ mm d2	Length total mm	Article No. toothing 6	Article No. toothing 5	Article No. toothing 1
Shank 3 mm						
3	11	3	38	9 376 816	9 376 772	—
3	16	3	38	9 376 817	9 376 774	—
Shank 6 mm						
6	19	6	50	9 376 857	9 376 776	—
9.5	16	6	63	9 376 858	9 376 778	—
12.7	22	6	69	9 376 859	9 376 780	9 376 896

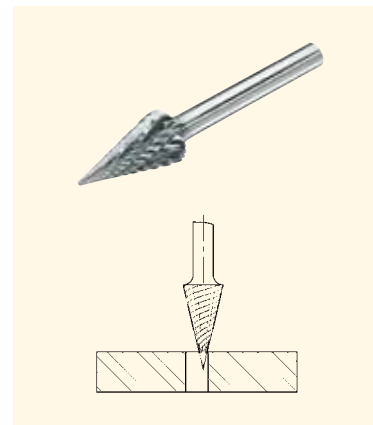

Hose units



Exemplary representation

Order numbers

For type	Hose unit complete	Supply air hose per running meter	Exhaust air hose per running meter	Thread socket
GT 652 D GTK 652 D	29911-55-5	9 361 532	9 361 214	47092-05-6
GTV 1000	29939-02-5	9 361 213	—	29300-63-6
G 813 D/H G 804 D G 604 D	29939-94-5	9 361 213	9 361 212	29939-93-3
G 551 D GK 551 D	29939-94-5	9 361 213	9 361 212	29939-93-3
G 452 D/H	29923-49-5	9 361 532	9 361 214	47092-05-6
G 357 D/H G 352 D/H	29923-49-5	9 361 532	9 361 214	47092-05-6
G 300 D/H	29923-49-5	9 361 532	9 361 214	47092-05-6
GK 282 D/H BSW 506	29923-49-5	9 361 532	9 361 214	47092-05-6
G 283 H G 236 H	29923-33-5	9 361 158	9 361 208	9 361 330
G 232 H G 120 H GL 120 H	29923-33-5	9 361 158	9 361 208	9 361 330
G 201 H	29923-33-5	9 361 158	9 361 208	9 361 330
GL 200 H	29923-33-5	9 361 158	9 361 208	9 361 330
GW 216 GW 218 H GW 126 H	29923-33-5	9 361 158	9 361 208	9 361 330
GB 815 H	29923-33-5	9 361 158	9 361 208	9 361 330
GW 122 H	60017-38-5	9 361 158	9 361 192	9 361 330
G 16000 H G 12000 H GL 16000 H GL 12000 H GL 20 000 H GLA 16000 H GLA 12000 H GW 121 H	60012-09-5	9 361 115	9 361 193	9 361 477
BSW 903	60012-24-5	9 361 213	9 361 212	29939-93-3
BS 502	29603-25-5	9 361 532	9 361 214	47092-05-6

Engraving pen

Writing, engraving and chiselling

- For writing and engraving on hardened steel, metal, glass, plastic, ceramic and stone
- Simple needle change
- Extremely low vibrations level below 2.5 m/s^2
- Noise level below 65 dB(A)
- GST 540 M for chiselling, fossils work



GST 540

Needle

Technical data

Type		GST 540	GST 540 M
Article No.		29903-91-6	29943-71-6
Valve		Rotary valve	Rotary valve
Frequency	Hz	540	540
Vibration	m/s^2	< 2.5	< 2.5
Noise level	dB(A)	65	65
Air consumption	l/sec	0.85	0.85
Weight without hose	kg	0.15	0.15
Ø machine	mm	17	17
Machine length	mm	162	162
Hose unit		included	included
Hose	m	2.5	2.5
Connection		plug-in socket	plug-in socket
Accessories supplied		needle, medium	chisel insert

Power and free speed at 6 bar operating pressure. Compressed air quality: lubricated.

Accessories for GST 540

Needle (tungsten carbide)

fine	29904-13-6
medium	29904-05-6
coarse	29904-14-6

Accessories for GST 540 M

Complete chisel head with chisel	29937-94-6
Complete chisel head with needle	29937-93-6
Chisel with spring	29937-92-6



GST 540 M

Filing machines

Deburring, filing works



FRV 60 B

FRV 110

- Deburring of cast or machined parts
- Filing applications in tool and mould making
- Extremely low vibration:
FRV 110: 2.0 m/s²
FRV 60 B: 1.8 m/s²
- FRV 110 for heavy-duty filing works
- High precision
- Calm run
- For files with round shank

Technical data

Type		FRV 60 B	FRV 110
Article No.		29900-07-6	29701-14-6
Valve		push button	lever valve
Number of blows	rpm	8 400	9 000
Frequency	Hz	140	150
Stroke max.	mm	4	8
Exhaust air		to the front	to the front
Ø tool holder max.	mm	3 – 4	4 6
Tool holder		clamping bolt	clamping bolt
Noise level	dB(A)	71	77
Air consumption	l/sec	0.5	1.3
Weight without hose	kg	0.30	1.05
Ø machine	mm	30	41
Machine length	mm	200	180
Hose I. D.	mm	3	6
Connection		—	G 1/4" i
Accessories supplied		wrench, hose 1.5 m	wrench

Power and free speed at 6 bar operating pressure. Compressed air quality: lubricated.

Accessories for FRV 110

Reduction collet 6/4 (for shanks 4 mm)	29931-44-6
----------------------------------------	------------



Swivel joint for FRV 110

Variacor	60001-60-6
----------	------------



Further Information see p. 74



Diamond file (detail)

Files for FRV 60 B

Ø shank 3.0 mm

Profile						
Cut 1 Article No.		9 376 906	9 376 907	9 376 908	9 376 909	9 376 910
Width × depth	mm	7.0 × 2.0	3.0 × 3.0	4.0 × 4.0	6.5 × 2.0	Ø 3.6
Useable length	mm	60	60	60	60	60
Ø shank	mm	3.0	3.0	3.0	3.0	3.0

Files for FRV 60 B

Ø shank 3.8 mm

Profile						
Cut 1 Article No.		9 376 921	9 376 922	9 376 924	9 376 926	9 376 928
Cut 0 Article No.		9 376 911	9 376 923	9 376 925	9 376 927	9 376 929
Width × depth	mm	7.0 × 2.0	3.0 × 3.0	4.0 × 4.0	6.5 × 2.0	Ø 3.6
Useable length	mm	60	60	60	60	60
Ø shank	mm	3.8	3.8	3.8	3.8	3.8

Diamond files for FRV 60 B

Ø shank 3.0 mm

Profile						
Grain D 107 Article No.		9 376 931	9 376 932	9 376 933	9 376 934	9 376 935
Width × depth	mm	5.2 × 1.4	2.5 × 2.5	3.6 × 3.6	5.0 × 2.0	Ø 3.0
Total length	mm	85	85	85	85	85
Useable length	mm	45	45	45	45	45
Ø shank	mm	3.0	3.0	3.0	3.0	3.0

Files for FRV 110

Ø shank 6.0 mm

Profile						
Cut 1 Article No.		9 376 900	9 376 901	9 376 902	9 376 903	9 376 904
Cut 0 (for alu) Article No.		9 376 912	—	—	—	—
Cut 1 Width × depth	mm	12.3 × 6.3	8.0 × 8.0	9.0 × 9.0	12.0 × 6.0	Ø 6.0
Cut 0 Width × depth	mm	12.0 × 7.0	—	—	—	—
Useable length	mm	80	80	80	80	80
Ø shank	mm	6.0	6.0	6.0	6.0	6.0

Orbital sanders



MDEXZ

- Without suction
- Ergonomic casing
- Powerful
- Low profile
- Very reliable on high load
- Two oscillating circuits:
2.5 and 5 mm swing
- With connector for dust extraction system upon request

Technical data

Type		MDEXZ 125/2.5	MDEXZ 125/5.0	MDEXZ 150/2.5	MDEXZ 150/5.0
Article No.		8280 0302	8280 0303	8280 0304	8280 0305
Ventil		lever valve	lever valve	lever valve	lever valve
Free speed	rpm	12 000	12 000	12 000	12 000
Power	Watt	209	209	209	209
Exhaust air		to the rear	to the rear	to the rear	to the rear
Spindle thread	mm	5/16 × 24	5/16 × 24	5/16 × 24	5/16 × 24
Velcro disc max.	mm	125	125	150	150
Noise level	dB(A)	79	79	79	79
Air consumption	l/sec	5.8	5.8	5.8	5.8
Weight without hose	kg	0.72	0.75	0.76	0.79
Machine height	mm	83	83	83	83
Machine length	mm	148	152	161	162
Hose I.D.	mm	8	8	8	8
Connection		G 1/4" i	G 1/4" i	G 1/4" i	G 1/4" i
Accessories supplied		Velcro disc, hose nozzle	Velcro disc, hose nozzle	Velcro disc, hose nozzle	Velcro disc, hose nozzle

Power and free speed at 6 bar operating pressure. Compressed air quality: lubricated.

Accessories

Velcro disc for MDEXZ 125	9368733
Velcro disc for MDEXZ 125	9368734



Velcro disc

Robot spindles
Air spindles
Built-in air motors



Let's hatch it out!

We advise you
broadly and competently
about robot spindles

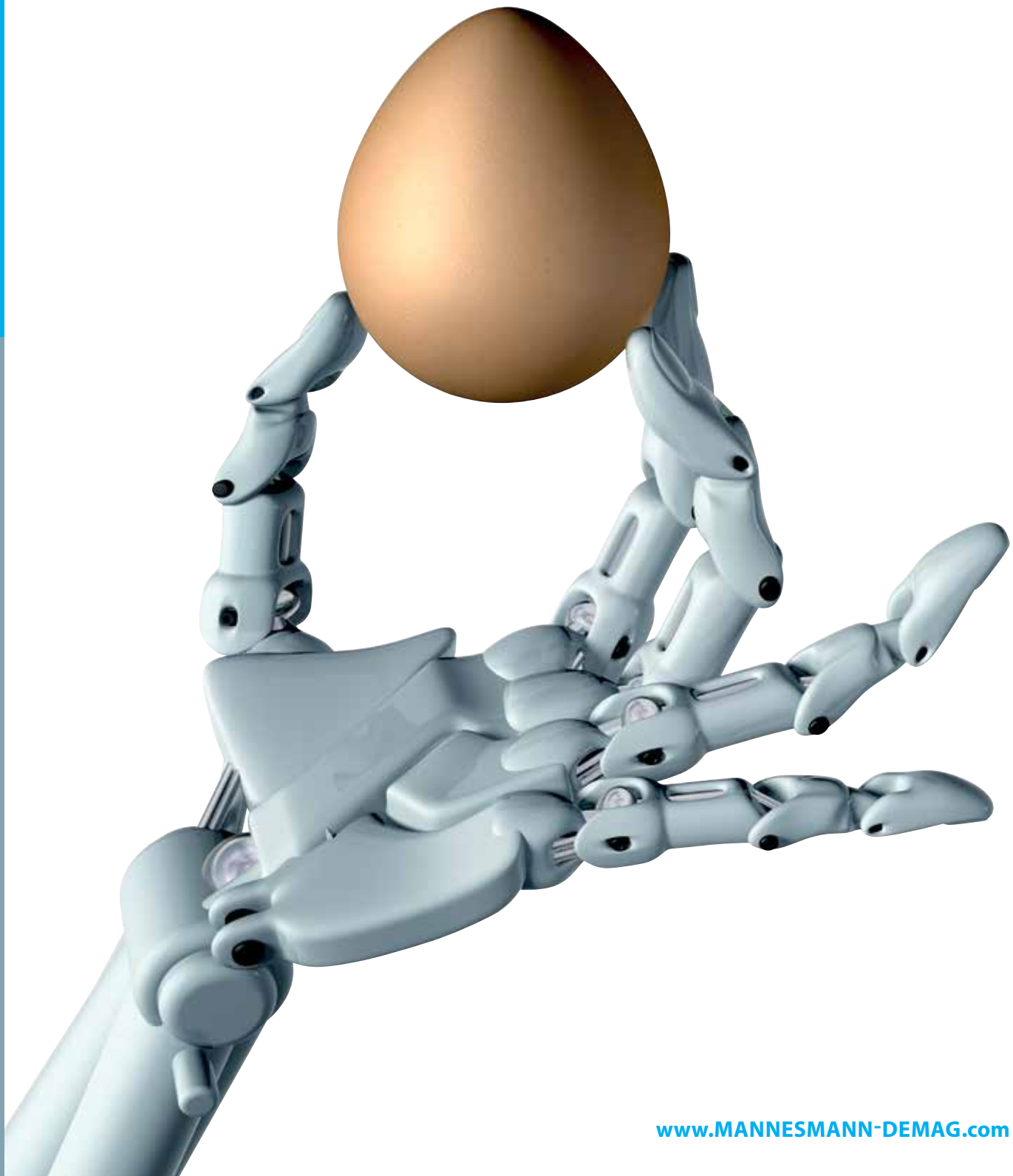

Robot spindles From our extensive program

Spindles with radial deflection for deburring and milling

- Free speed: 15 000 – 100 000 min⁻¹
- Power: 100 – 800 Watt



ESR 1000



ESR 551



ESR 350



ESR 170

Spindles with radial or axial deflection for brushing

- Free speed: 520 – 20 000 min⁻¹
- Power: 380 – 840 Watt



ESR 38-520 AX25



ESR 50



SSU 60

Robot spindles

From our extensive program

Axial and radial compensation with quick change chuck and / or sensors

Free speed up to 20 000 min⁻¹



ESR with radial deflection and quick change chuck



ESR with axial deflection and quick change chuck



ESR 30 AX25 ST axial deflection with sensors

Radial see-saw compensation unit with sensor control

With this modular deflection unit you can combine many air motors, chamfering tools, filing machines or grinding spindles.

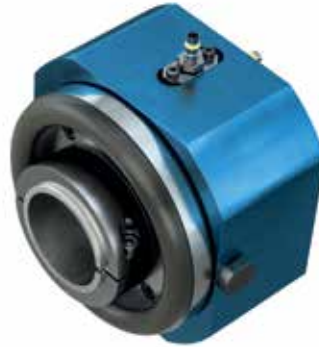

Numerous combinations

Robot spindles From our extensive program

Robot spindles for use with in CNC machines

With maximum speed to the peak of productivity:
Save up to 80 % machining time with highest cutting rates
and up to 300 m/min feeding speed.



ESR 1000 X3



ESR 350 X3



ESK 1000 ARF SK40



ESK 350 ARF SK40

We test your individual deburring task

We test your specific deburring task with our robot
and advise you on basis of our test results and our
experience of many years regarding deburring tasks.



UR 10 Testing system

- Quick change chuck page 46
- Speed control sensor page 44
- Find the latest info and the complete program at:
www.MANNESMANN-DEMAG.com

Air spindles



ES 804 ER

ES 550 ZG

ES 350 ER

Technical data

Type		ES 804 ER	ES 550 ZG	ES 350 ER
Article No.		60051-24-7	29924-59-7	60012-15-7
Free speed	rpm	80 000	55 000	35 000
Power	Watt	110	70	300
Direction of rotation		clockwise	clockwise	clockwise
Exhaust air		to the rear	to the rear	to the rear
Collet included	mm	3	3	6
Collets available	mm	—	1.0 1.5 2.0 2.5 3/32" 1/8"	3 4 5
Carbide burrs	max. mm	4	4	10
Mounted points and wheels	max. mm	6	6	16
Noise level	dB(A)	80	75	79
Air consumption	l / sec	3.0	2.3	8.3
Weight	kg	0.11	0.08	0.42
Connection air supply (hose)	∅ mm, inside /outside	4 6	4 6	6 8

Power and free speed at 6 bar operating pressure. Compressed air quality: lubricated.

- For installation in transfer lines, machine tools and robot stations
- Stainless steel housings
- Stainless steel collet spindles
- Small dimensions
- High true-running accuracy
- 100 % overload capacity
- Paired ball bearings for longer tool life time and better operating characteristic (except ES 550 ZG)
- With rotating splashguard to prevent penetration of dust, water or chips (except ES 550 ZG)



Technical data

Type		ES 280 ER	ES 200 ER	ES 170 ER
Article No.		29924-52-7	60008-32-7	29924-44-7
Free speed	rpm	28 000	20 000	15 000
Power	Watt	380	400	800
Direction of rotation		clockwise	clockwise	clockwise
Exhaust air		to the rear	to the rear	to the rear
Collet included	mm	6	6	8
Collets available	mm	3 5 8 10	3 5 8 10	3 5 6 10
Carbide burrs	max. mm	10	12	15
Mounted points and wheels	max. mm	16	25	32
Noise level	dB(A)	80	72	86
Air consumption	l/sec	11.5	8.5	15.8
Weight	kg	0.75	1.10	1.65
Connection air supply (hose)	∅ mm, inside /outside	10 12	10 12	10 12

Power and free speed at 6 bar operating pressure. Compressed air quality: lubricated.

- For installation in transfer lines, machine tools and robot stations
- Stainless steel housings
- Stainless steel collet spindles
- Small dimensions
- High true-running accuracy
- 100 % overload capacity
- Paired ball bearings for longer tool life time and better operating characteristic
- With rotating splashguard to prevent penetration of dust, water or chips

Air spindles

Non-lubricated turbines



EST 1000 ZG



EST 1000 K | EST 650 K

Technical data

Type		EST 1000 ZG	EST 1000 K	EST 650 K
Article No.		Impeller turbine 29924-61-7	Jet turbine 29939-57-7	Jet turbine 29939-58-7
Free speed	rpm	100 000	80 000	65 000
Power	Watt	100	100	70
Direction of rotation		clockwise	clockwise	clockwise
Exhaust air		to the front	to the rear	to the rear
Collet included	mm	3	3	3
Collets available	mm	1.0 1.5 2.0 2.5 3/32" 1/8"	1.0 1.5 2.0 2.5 3/32" 1/8"	1.0 1.5 2.0 2.5 3/32" 1/8"
Carbide burrs	max. mm	3	3	3
Mounted points and wheels	max. mm	5	5	5
Noise level	dB(A)	74	69	69
Air consumption	l / sec	5.3	3.5	3.5
Weight	kg	0.25	0.26	0.26
Connection air supply (hose)	Ø mm, inside / outside	2.7 4	6 8	6 8

Power and free speed at 6 bar operating pressure. Compressed air quality: non-lubricated.

- For installation in transfer lines, machine tools and robot stations
- Stainless steel housings
- Stainless steel spindles
- Floating spindle support
- High revolutions for excellent processing quality
- Maintenance-friendly
- High true-running accuracy for long tool life
- EST 650: centrifugal governor



EBS 504 ZG

EBS 520 ER

EWBS 38-520

EBS 520 WK

Technical data

Type		EBS 504 ZG	EBS 520 ER	EBS 520 WK	EWBS 38-520
Article No.		29937-30-7	60001-36 -7	60003-50-7	60001-29-5
Free speed	rpm	500	520	520	520
Power	Watt	160	380	380	380
Start-up		push start	external	external	external
Direction of rotation		clockwise	clockwise	clockwise	clockwise
Exhaust air		to the rear	to the rear	to the rear	to the rear
ER collet		—	—	10 mm	1/4"– 6 kt.
Collet included	mm	8	8	—	—
Collets available	mm	5 6 1/4" 10	3 5 6 10	—	—
Radial compliance of coupling		—	—	± 7°	—
Radial off-set of coupling max.	mm	—	—	± 0.5	—
Noise level	dB(A)	65	—	—	—
Air consumption	l / sec	5.3	8.5	8.5	8.5
Weight	kg	0.75	1.40	1.20	2.30
Air supply hose	∅ mm / i	—	8	8	8
Exhaust air hose	∅ mm / i	—	10	10	10
Connection air supply (hose)	∅ mm, inside /outside	6 8	—	—	—

Power and free speed at 6 bar operating pressure. Compressed air quality: lubricated.

- For installation in transfer lines, machine tools and robot stations
- Stainless steel housings
- Stainless steel collet spindles
- Ideal for chamfering and brushing

- Collets up to 10 mm
- Type EBS 520: Splash guard to protect against dust, water and chips
- Push start of EBS 504 lowers air consumption

- Type EBS 520 WK: With spiral coupling to compensate radial or axial offset, chamfering tool shaft diameter 10 mm, shaft length max. 10 mm

Accessories

HSS-counter sink	EWBS 38-520
3 teeth, 1/4" hex. / 90°	
Sinking range 2.5 – 10 mm	48109-21-6
Sinking range 3.2 – 16.5 mm	48109-22-6
Sinking range 5 – 25 mm	48109-24-6

Built-in air motors

With collet and speed sensor



EBM 5200 S

EBM 19000 S-ST

Technical data

Type with collet (clockwise)		EBM 19000 S	EBM 5200 S	EBM 2900 S	EBM 2400 S	EBM 1200 S
Article No.		29945-61-7	60003-64-7	29948 33 7	60003-63-7	60015-38-7
Type with speed sensor (clockwise)		EBM 19000 S-ST	EBM 5200 S-ST	EBM 2900 S-ST	EBM 2400 S-ST	EBM 1200 S-ST
Article No.		60054-91-7	60058-01-7	60058-02-7	60058-03-7	60058-04-7
Free speed	rpm	19 000	5 200	2 900	2 400	1 200
Power	Watt	380	380	380	380	380
Collet included	mm	6	6	6	6	6
Collets available	mm	3 5 8 10	3 5 8 10	3 5 8 10	3 5 8 10	3 5 8 10
Direction of rotation		clockwise	clockwise	clockwise	clockwise	clockwise
Exhaust air		to the rear	to the rear	to the rear	to the rear	to the rear
Air consumption	l/sec	8.5	8.5	8.5	8.5	8.5
Weight	kg	1.12	1.12	1.12	1.12	1.42
Air supply hose	∅ mm / i	8	8	8	8	8
Exhaust air hose	∅ mm / i	10	10	10	10	10

Power and free speed at 6 bar operating pressure. Compressed air quality: lubricated.

- For installation in transfer lines, machine tools and robot stations
- Stainless steel housings
- Stainless steel collet spindles
- Ideal for drilling or brushing
- Without valve, for central remote control
- Small housing diameter for minimum centre-to-centre spacing
- Reversible EBMU Types
- Splash guard to protect against dust, water and chips

EBM-ST-models

Technical details

- Integrated inductive sensor (M5)
- Real working speed control for uniform results
- Data reading and analysis by superordinate control or separately available control unit
- To protect against collision
- Re-adjustment or replacement advice on higher speed caused by tool wear
- Early detection of motor wear on decreasing speed

The suitable accessories:
page 49 and 50.

Built-in air motors With drill chuck



EBM 38-5200 B

EBM 38-5200 B

Technical data

Type		EBM 38-5200 B	EBM 38-2900 B	EBM 38-2400 B	EBM 38-1200 B
Article No.		60053-66-7	60019-47-7	60058-05-7	60008-71-7
Free speed	rpm	5 200	2 900	2 400	1 200
Power	Watt	380	380	380	380
Drill chuck clamp. range	mm	1 – 10	1 – 10	1 – 10	1 – 10
DIN taper or thread		3/8" × 24 UNF	3/8" × 24 UNF	3/8" × 24 UNF	3/8" × 24 UNF
Direction of rotation		clockwise	clockwise	clockwise	clockwise
Exhaust air		to the rear	to the rear	to the rear	to the rear
Air consumption	l/sec	8.5	8.5	8.5	8.5
Weight	kg	1.20	1.20	1.20	1.50
Air supply hose	∅ mm / i	8	8	8	8
Exhaust air hose	∅ mm / i	10	10	10	10

Power and free speed at 6 bar operating pressure. Compressed air quality: lubricated.

- For installation in transfer lines, machine tools and robot stations
- Stainless steel housings
- Ideal for drilling or brushing
- Without valve, for central remote control
- Small housing diameter for minimum centre-to-centre spacing

The suitable accessories:
page 49 and 50.



Throttle with silencer

Speed can be adjusted accurately if a throttle silencer is used.
(Article No. 9361705)



Oil trap

Using an oil trap the exhaust air can be filtered up to 99%.
(Article No. 60025-98-6)

Built-in air motors

With quick-change chuck

230 – 380 W



EBM 38-5200 WS

Tool change with fork

Technical data

Type		EBMU 23-14000 WS	EBMU 23-4000 WS	EBMU 23-2000 WS	EBM 38-19000 WS	EBM 38-5200 WS	EBM 38-2400 WS
Article No.		60037-48-7	60038-54-7	60038-57-7	60051-92-7	60038-62-7	60038-63-7
Free speed	rpm	14 000	4 000	2 000	19 000	5 200	2 400
Power	Watt	230	230	230	380	380	380
Direction of rotation		reversible	reversible	reversible	clockwise	clockwise	clockwise
Exhaust air		to the rear	to the rear	to the rear	to the rear	to the rear	to the rear
Air consumption	l/sec	7.8	7.8	7.8	8.3	8.3	8.3
Weight	kg	1.8	1.8	1.8	1.8	1.8	1.8
Air supply hose	Ø mm / i	8	8	8	8	8	8
Exhaust air hose	Ø mm / i	10	10	10	10	10	10

Power and free speed at 6 bar operating pressure. Compressed air quality: lubricated.

- Ideal for **brushing**
- Manual brush change or automatic tool change for robot systems

Necessary accessories – please order separately

- Collet holder
- + ER collet
- + nut
- or
- holder with M 14 × 2 thread



Fork



Brush holder



Holder M 14 × 2



Nut

Accessories

Fork for automated tool change	60036-02-5
Collet holder	60050-24-3
Holder with M 14 × 2 thread	60050-38-3
Nut	29701-56-3
Speed throttle 1/2"	9 361 705

Tools to be changed will be prepared in a secondary process and can be integrated within very short time

Built-in air motors With quick-change chuck 500 – 620 W



EBM 55-5600 WS

Tool change with fork

Technical data

Type		EBMU 40-4800 WS	EBMU 40-3000 WS	EBM 55-5600 WS	EBM 55-3600 WS
Article No.		60038-29-7	60038-28-7	60038-27-7	60038-69-7
Free speed	rpm	4 800	3 000	5 600	3 600
Power	Watt	500	500	620	620
Direction of rotation		reversible	reversible	clockwise	clockwise
Exhaust air		to the rear	to the rear	to the rear	to the rear
Air consumption	l / sec	12.6	12.6	14.6	14.6
Weight	kg	2.3	2.3	2.3	2.3
Air supply hose	Ø mm / i	10	10	10	10
Exhaust air hose	Ø mm / i	16	16	16	16

Power and free speed at 6 bar operating pressure. Compressed air quality: lubricated.

- Ideal for **brushing**
- Manual brush change or automatic tool change for robot systems

Necessary accessories – please order separately

Collet holder
+ ER collet
+ nut
or
holder with M 14 × 2 thread



Fork



Brush holder



Holder M 14 × 2



Nut

Accessories

Fork for automated tool change	60036-02-5
Collet holder	60050-24-3
Holder with M 14 × 2 thread	60050-38-3
Nut	29701-56-3
Speed throttle 1/2 "	9 361 706

Tools to be changed will be prepared in a secondary process and can be integrated within very short time

Built-in air motors

With quick-change chuck

820 – 1 200 W



Example: Tool change with fork



... or manually



EBM 120-1200 WS

Technical data

Type		EBMU 82-13600 WS	EBMU 82-4000 WS	EBMU 82-850 WS	EBM 120-18600 WS	EBM 120-5400 WS	EBM 120-1200 WS
Article No.		60038-65-5	60038-73-5	60038-74-5	60038-70-5	60038-71-5	60038-72-5
Free speed	rpm	13 600	4 000	850	18 600	5 400	1 200
Power	Watt	820	820	820	1 200	1 200	1 200
Direction of rotation		reversible	reversible	reversible	clockwise	clockwise	clockwise
Exhaust air		to the rear	to the rear	to the rear	to the rear	to the rear	to the rear
Air consumption	l / sec	18	18	18	23	23	23
Weight	kg	3.4	3.4	3.4	3.4	3.4	3.4
Air supply hose	Ø mm / i	13	13	13	13	13	13
Exhaust air hose	Ø mm / i	16	16	16	16	16	16

Power and free speed at 6 bar operating pressure. Compressed air quality: lubricated.

- Ideal for **brushing**
- Manual brush change or automatic tool change for robot systems

Necessary accessories – please order separately

- Collet holder
- + ER collet
- + nut
- or
- holder with M 14 × 2 thread



Fork



Brush holder



Holder M 14 × 2



Nut

Accessories

Fork for automated tool change	60036-02-5
Collet holder	60050-24-3
Holder with M 14 × 2 thread	60050-38-3
Nut	29701-56-3
Speed throttle 1/2"	9 361 708

Tools to be changed will be prepared in a secondary process and can be integrated within very short time

Examples



Spindles | ZG collets

Clamping range \varnothing (mm|")

Types	page	1.0	1.5	2.0	2.5	3/32"	3.0	1/8"
EST 1000 ZG	42	9 369 912	9 369 913	9 369 914	9 369 915	9 369 916	9 369 825	9 369 917
EST 1000 K	42	9 369 912	9 369 913	9 369 914	9 369 915	9 369 916	9 369 825	9 369 917
EST 650 K	42	9 369 912	9 369 913	9 369 914	9 369 915	9 369 916	9 369 825	9 369 917
ES 550 ZG	40	9 369 912	9 369 913	9 369 914	9 369 915	9 369 916	9 369 825	9 369 917

Spindles | ER collets

Types	page	3.0	4.0	5.0	6.0	8.0	10.0
ES 804 ER	40	9 369 993	—	—	—	—	—
ES 350 ER	40	9 369 853	9 369 849	9 369 838	9 369 832	—	—
ES 280–170 ER	41	9 369 855	—	9 369 850	9 369 839	9 369 842	9 369 852

Motors | ZG collets

Types	page	3.0	4.0	5.0	6.0	8.0	1/4"	10.0
EBS 504 ZG	43	—	—	9 369 816	9 369 837	9 369 818	9 369 987	9 369 817

Motors | ER collets

Types	page	3.0	4.0	5.0	6.0	8.0	10.0
all EBM	44	9 369 855	9 369 884	9 369 850	9 369 839	9 369 842	9 369 852
EBM / EBMU w. SWF	46–48	9 369 855	9 369 884	9 369 850	9 369 839	9 369 842	9 369 852
EBS 520 ER	43	9 369 855	9 369 884	9 369 850	9 369 839	9 369 842	9 369 852

Motors | Drill chucks, drill chuck keys

Types	page	drill chuck	drill chuck key	quick change drill chuck
all EBM 38-... B	45	9 376 022	9 369 811	9 369 988

Speed throttle with silencer

Tap	G 1/8"	G 1/4"	G 3/8"	G 1/2"
Article No.	9361 707	9361 705	9361 706	9361 708

Silencer

Tap	G 1/4"	G 3/8"	G 1/2"	G 3/4"	G 1"
Article No.	47004-18-6	49589-03-6	49589-02-6	49589-00-6	49589-01-6

Oil trap

- Design: Silencer with filter
- Mounting: upright
- Operating pressure min. / max.: 0 / 10 bar
- Medium: Compressed air
- Temperature range min. / max.: - 10 / + 60 °C
- Housing: aluminum
- Filter end cap: steel
- Cask and collecting pan: Polyoxymethylene

Article No.	60025-98-6	60025-96-6	
Threaded Connection	G 1/2 "	G 1 "	
Nominal flow	l / min	2 500	3 500
Weight	kg	0.74	1.25
Max. residual lubricant content	mg / m ³	0.01	0.01
Filter efficiency	99.99 %	99.99 %	
Silencing	up to 40 dB(A)	up to 40 dB(A)	



Oil trap

Always up to date.
Find dimensional drawings
for our built-in air motors at
www.MANNESMANN-DEMAG.com

Drilling and cutting





MANNESMANN DEMAG drilling and cutting tools are distinguished by:

- Ergonomic design
- Low air consumption
- Very low noise levels
- Absolutely easy to service and uncomplicated to maintain
- Modular systems: various assemblies are interchangeable
- Conception for precise as well as for rugged industrial applications



Drills

Our wide range – drilling from 1 to 50 mm, with straight, angled or pistol grip designs – guarantees suitable drilling in all applications. The choice of the right drill is determined firstly by the drilling diameter, the material and the cutting speed which is required.

Countersinks

Our countersinks offer a perfect program for all deburring works, which must be accomplished by hand. The countersinks are ideal tools to deburr, spot face or chamfer steel, cast iron, non-ferrous or light metals. The low and variable cutting speed ensures best working results.

Tapping machines

MANNESMANN DEMAG tapping machines are in the best way suitable for cutting and cleaning threads. Grace to the optimized power-weight ratio and the handy design the tools offer opportunities for all kind of manufacturing applications. Our tapping tools are equipped with a two jaw pendular chuck with a round wedge.

→ Simply work more rational – with MANNESMANN DEMAG drills, countersinks and tapping machines.

Drills (pistol grip)

With gear rim drill chuck

- Exhaust silencer is built into the pistol grip so that there is no disruptive exhaust air
- Compact design
- Ergonomical aluminium handle
- Low maintenance
- Air supply through handle
- D 6-55 P also suitable for sinking



1 | 2

Technical data

Type		D 6-501 P	D 6-351 P	D 6-55 P	D 8-6000 P	D 8-2800 P
Order No.		03138-77-4	03138-97-4	03255-00-5	29919-70-5	46910-46-5
Illustration		1	1	1	2	2
Free speed	rpm	5 000	3 500	550	6 000	2 800
Power	Watt	150	150	150	320	320
DIN taper		B 10	B 10	B 10	B 12	B 12
Drill chuck clamp. range	mm	1 – 6	1 – 6	1 – 6	1 – 8	1 – 8
Drilling capacity steel	mm	4	4	4	6	6
Drilling capacity alumin.	mm	6	6	6	10	10
Noise level	dB(A)	69	69	69	75	75
Air consumption	l/sec	5.3	5.3	5.3	7.0	7.0
Weight without hose	kg	0.60	0.60	0.65	1.00	1.00
Ø machine	mm	31	31	31	38	38
Machine length	mm	162	162	188	195	198
Hose I.D.	mm	6	6	6	6	6
Connection		G 1/4" i	G 1/4" i	G 1/4" i	G 1/4" i	G 1/4" i
Accessories supplied		drill chuck key	drill chuck key	drill chuck key	drill chuck key	drill chuck key

Power and free speed at 6 bar operating pressure. Compressed air quality: lubricated.

Accessories



For type	D 6-501 P	D 6-351 P	D 6-55 P	D 8-6000 P	D 8-2800 P
Gear rim drill chuck	9 376 019	9 376 019	9 376 019	9 376 014	9 376 014
Drill chuck key	9 369 811	9 369 811	9 369 811	9 369 811	9 369 811
Quick change drill chuck	9 369 990	9 369 990	9 369 990	9 369 988	9 369 988

- Exhaust silencer is built into the pistol grip so that there is no disruptive exhaust air
- Compact design
- Ergonomical aluminium handle
- Low maintenance
- Air supply through handle
- D 13-45 P with quick change drill chuck

Drills (pistol grip) With gear rim drill chuck



1



2



3

Technical data

Type		D 10-1800 P	D 13-900 P	D 13-380 P	D 13-45 P	D 15-600 P	D 15-1800 P
Order No.		46920-36-5	46920-37-5	46920-39-5	29900-01-6	47470-53-5	47420-53-5
Illustration		1	1	1	2	3	3
Free speed	rpm	1 500	900	380	450	600	1 800
Power	Watt	320	320	300	400	520	520
DIN taper		B 12	B 12	B 12	1/2" x 20 UNF	3/8" x 24 UNF	3/8" x 24 UNF
Drill chuck clamp. range	mm	1 – 10	1 – 13	1 – 13	1.5 – 13	3 – 13	3 – 13
Drilling capacity steel	mm	8	8	8	13	13	8
Drilling capacity alumin.	mm	12	12	12	20	20	12
Noise level	dB(A)	75	75	75	79	77	77
Air consumption	l/sec	7.0	7.0	7.0	9.0	11.3	11.3
Weight without hose	kg	1.10	1.25	1.30	1.90	2.40	1.25
Ø machine	mm	38	38	38	45	54	54
Machine length	mm	232	234	240	260	247	226
Hose l. D.	mm	8	8	10	10	10	10
Connection		G 1/4" i	G 1/4" i	G 1/4" i	G 1/4" i	G 1/4" i	G 1/4" i
Accessories supplied		drill chuck key	drill chuck key	drill chuck key	side handles	drill chuck key	drill chuck key

Power and free speed at 6 bar operating pressure. Compressed air quality: lubricated.

Accessories



For type	D 10-1800 P	D 13-900 P	D 13-380 P	D 13-45 P	D 15-600 P	D 15-1800 P
Gear rim drill chuck	9 376 014	9 376 017	9 376 017	—	9 369 821	9 369 821
Drill chuck key	9 369 811	9 376 018	9 376 018	—	9 376 018	9 376 018
Quick change drill chuck	9 369 989	9 369 991	9 369 991	9 369 992	—	—
Side handles	—	—	—	29943-42-6	47409-00-5	47409-00-5

Drills (straight)

With gear rim drill chuck

- Suitable for vertical drilling work
- Exhaust air to the rear
- Very low-noise
- Suitable for brushing
- Handy and light-weight



1

Technical data

Type		D 6-5000 H	D 6-3500 H	D 8-6002 H	D 8-3702 H	D 8-2802 H
Article No.		48100-30-5	48100-31-5	29945-33-5	29945-34-5	29945-35-5
Illustration		1	1	1	1	1
Valve		lever valve	lever valve	lever valve	lever valve	lever valve
Free speed	rpm	6 000	3 500	6 000	3 700	2 800
Power	Watt	150	150	320	320	320
DIN taper		B 10	B 10	B 12	B 12	B 12
Drill chuck clamp. range	mm	1 – 6	1 – 6	1 – 10	1 – 10	1 – 10
Drilling capacity steel	mm	4	5	6	6	6
Drilling capacity alumin.	mm	6	8	10	10	10
Noise level	dB(A)	67	67	70	70	70
Air consumption	l / sec	4.2	4.2	5.3	5.3	5.3
Weight without hose	kg	0.70	0.70	1.20	1.20	1.20
Ø machine	mm	31	31	38	38	38
Machine length	mm	195	195	222	222	226
Hose I. D.	mm	6	6	6	6	6
Connection		G 1/4" i	G 1/4" i	G 1/4" i	G 1/4" i	G 1/4" i
Accessories supplied		drill chuck key	drill chuck key	drill chuck key, hose unit	drill chuck key, hose unit	drill chuck key, hose unit

Power and free speed at 6 bar operating pressure. Compressed air quality: lubricated.

Accessories



For type	D 6-5000 H	D 6-3500 H	D 8-6002 H	D 8-3702 H	D 8-2802 H
Gear rim drill chuck	9 376 019	9 376 019	9 376 014	9 376 014	9 376 014
Drill chuck key	9 369 811	9 369 811	9 369 811	9 369 811	9 369 811
Quick change drill chuck	9 369 990	9 369 990	9 369 988	9 369 988	9 369 988
Hose unit	29200-31-5	29200-31-5	29923-33-5	29923-33-5	29923-33-5

Hose unit incl. air supply and air exhaust hose.

- Suitable for vertical drilling work
- Exhaust air to the rear
- Very low-noise
- DS-model with collet suitable for brushing
- Handy and light-weight

Drills (straight) With collet



Technical data

Type		DS 6000-100 H	DS 6002 H	DS 6-5000 H	DS 8-2802 H
Article No.		60016-00-5	29945-99-5	48100-20-5	29945-36-5
Illustration		1	3	2	3
Valve		lever valve	lever valve	lever valve	lever valve
Free speed	rpm	6 000	6 000	5 000	2 800
Power	Watt	320	320	150	320
Collet included	mm	6	6	6	8
Noise level	dB(A)	70	70	67	70
Air consumption	l/sec	5.3	5.3	4.2	5.3
Weight without hose	kg	1.30	1.00	0.70	1.10
Ø machine	mm	38	38	31	38
Machine length	mm	311	197	180	197
Hose I. D.	mm	6	6	6	6
Connection		G 1/4" i	G 1/4" i	G 1/4" i	G 1/4" i
Accessories supplied		Collet, wrench, hose unit	Collet, wrench, hose unit	Collet, wrench	Collet, wrench, hose unit

Power and free speed at 6 bar operating pressure. Compressed air quality: lubricated.

Accessories



For type	DS 6000-100 H	DS 6002 H	DS 6-5000 H	DS 8-2802 H
Collet 6 mm	9 369 891	9 369 826	9 369 918	9 369 826
Collet 8 mm	—	9 369 843	—	9 369 843
Hose unit	29923-33-5	29923-33-5	29200-31-5	29923-33-5

Hose unit incl. air supply and air exhaust hose.

Angle drills

With Morse taper

- The speed regulator fitted as standard ensures that a constant speed can be maintained, even under the smallest load
- This means that there is very little wear on the vanes
- Drill bits are changed by means of a feed screw
- The very small centre-to-centre distance allows the drills to be used close to walls



D 3350

D 3400

Clockwise turning | Technical data

Type		D 3300	D 3350	D 3400	D 3450
Article No.		43300-00-6	43350-00-6	43400-00-6	43450-00-6
Direction of rotation		clockwise	clockwise	clockwise	clockwise
Drilling in steel up to	mm	15	23	32	50
Reaming up to	mm	12	18	27	36
Morse taper		1	2	3	4
Free speed	rpm	1 000	400	400	300
Air consumption, under load	m ³ /min	0.6	1.6	2.1	2.2
Air consumption, at free speed	m ³ /min	0.6	0.7	0.8	1.0
Power	kW	0.48	1.50	2.10	2.20
Length	mm	318	446	480	507
Height	mm	141	193	215	239
Feed via feed screw	mm	45	60	75	75
Distance from centre of spindle to outer edge	mm	25	30	35	40
Weight	kg	2.9	8.3	11.7	13.9
Hose I. D.	mm	10	15	15	19
Connection		G 3/8" i	G 1/2" i	G 1/2" i	G 1/2" i

Power and free speed at 6 bar operating pressure.



Accessories supplied

For type	D 3300	D 3350	D 3400	D 3450
External thread coupling	9 361 337	9 361 338	9 361 337	9 361 338

- Angle drills with collet for difficult to access areas
- Quick-action drill chuck on request
- Lever start
- Exhaust air to the rear

Angle drills With gear rim drill chuck, collet



DW 2200



DWS 2201



DW 700

Technical data

Type		DW 2200	DWS 2201	DW 700
Article No.		29945-65-6	60026-52-6	29945-66-6
Valve		lever valve	lever valve	lever valve
Free speed	rpm	2 200	2 200	700
Power	Watt	300	300	300
Collet	mm	—	6	—
Drill chuck clamping range	mm	1 – 8	—	1 – 10
Taper DIN		3/8" × 24 UNF	—	3/8" × 24 UNF
Noise level	dB(A)	76	76	76
Air consumption	l/sec	9	9	9
Length	mm	255	255	285
Head height	mm	83	54	90
Ø machine	mm	40	40	40
Weight	kg	1.10	1.00	1.30
Connection	G	1/4" i	1/4" i	1/4" i
Hose I. D.	mm	8	8	8
Accessories supplied		drill chuck key	wrench, collet	drill chuck key

Power and free speed at 6 bar operating pressure. Compressed air quality: lubricated.

Accessories



Gear rim drill chuck	DW 2200	DWS 2201	DW 700
Article No.	9 376 023	—	9 376 022
Collets			
3 mm	—	9 369 853	—
5 mm 3/16"	—	9 369 838	—
6 mm	—	9 369 832	—

Collets

1 | 1.5 | 3.5 | 4.5 | 5.5 mm
available on request.

Countersinks

Deburring of drillings



BS 502

BS 500 P

- Extremely quiet and robust
- Automatic start as soon as pressure is applied (Type BS 502)
- Low air consumption, as drive is only active during actual operation
- Thus leading to longer service life
- Suitable for additional activities during the main production time on CNC machine tools
- Cold-insulating handle
- The ergonomic design of the handle means that work is non-tiring
- BS 502, BSW 903 and BSW 506 with speed regulator
- The ease of operation is supported by a starter button on the type BS 500 P
- BSW 903 and BSW 506 (angle version) for deburring of places only accessible with difficulty, e. g. holes with cross sections

Technical data

Type		BS 502	BS 500 P	BSW 903	BSW 506
Article No.		29602-46-5	29500-32-5	60012-08-5	29945-64-5
Valve		push start	starter button	lever valve	lever valve
Free speed	rpm	500	500	900	500
Speed regulator		ja	—	ja	ja
Power	Watt	160	160	35	65
Chamfering range	mm	5 – 30	5 – 30	2 – 10	5 – 25
Collet included	mm	8	8	3 skt	1/4" skt
Collet optional	mm	6, 10	6, 10	—	—
Noise level	dB(A)	65	63	68	71
Air consumption	l/sec	5.0	5.0	2.8	5.0
Weight without hose	kg	0.65	0.78	0.40	0.85
Ø machine	mm	31	31	25	30
Machine length	mm	230	190	258	295
Head height without counterbore	mm	—	—	18	30.5
Hose unit					
Supply air hose	m	1.5	—	1.5	1.5
Exhaust air hose	m	1	—	1	1
Connection		G 1/4"	G 1/4" i	G 1/4"	G 1/4"
Accessories supplied		drill chuck key	drill chuck key	—	—

Power and free speed at 6 bar operating pressure. Compressed air quality: lubricated.



BSW 903

BSW 506

Countersinks

Deburring of drillings



HSS counterbore BS



HSS counterbore BSW 506



HSS counterbore BSW 903

HSS counterbores

For types BS 502 and BS 500 P

3 teeth, shaft 8 \varnothing / 90°

Sinking range 3.5 – 14 mm	48109-11-6
Sinking range 5 – 25 mm	48109-10-6
Sinking range 5 – 30 mm	48109-09-6

For type BSW 506

3 teeth, 1/4" hexagon / 90°

Sinking range 2.5 – 10 mm	48109-21-6
Sinking range 3.2 – 16,5 mm	48109-22-6
Sinking range 3.5 – 20.5 mm	48109-23-6
Sinking range 5 – 25 mm	48109-24-6

For type BSW 903

3 teeth, 3 mm hexagon / 90°

Sinking range 2 – 6 mm	48109-26-6
Sinking range 2 – 10 mm	48109-25-6

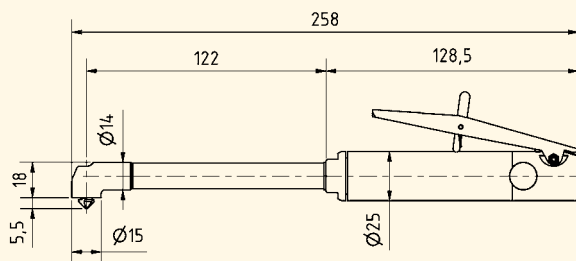

BSW 903

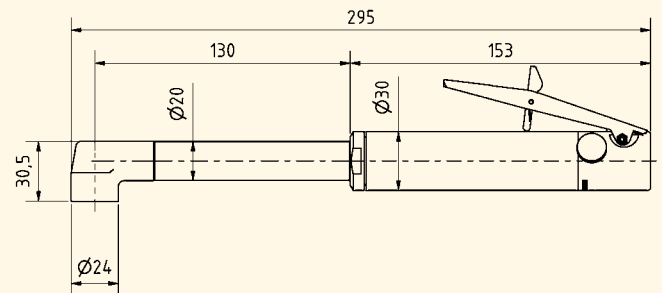

BSW 506

Accessories

Hose unit	BS 502	BS 500 P	BSW 903	BSW 506
Article No.	29603-25-5	—	60012-24-5	29923-49-5
Collets				
6 mm	9 369 837	9 369 837	—	—
8 mm	9 369 818	9 369 818	—	—
10 mm	9 369 817	9 369 817	—	—

Tapping machines



GE 8-500 P



G 14-6 P

- Handy-ergonomic aluminium handle
- Quiet, high power
- Reversible forward and return speed with rocker
- Efficient operation: pendular chuck makes it easy to start the cut
- Optimum cutting power
- Backward speed twice that of forward motion on model G 14-6 P
- Model G 14-6 P: reversing gear
- Available with quick change chuck upon request
- For standard thread taper holder up to 11 x 9 are available

Technical data

Type		GE 8-500 P	GE 8-900 P	G 14-6 P
Article No.		47060-06-5	47060-08-5	47650-53-5
Free speed	rpm	500	900	600
Power	Watt	200	200	550
Pendular chuck		Ja	Ja	Ja
Square clamping range	mm	3 – 9	3 – 9	6 – 9
Taper DIN 238		B 12	B 12	B 12
Tapping in steel	mm	M 6	M 6	M 14
Tapping in aluminium	mm	M 8	M 8	M 16
Ø machine	mm	38	38	52
Machine length	mm	251	251	318
Noise level	dB(A)	77	77	78
Weight without hose	kg	1.20	1.20	2.20
Air consumption	l/sec	4.5	4.5	9.0
Hose I.D.	mm	6	6	10
Connection		G 1/4" i	G 1/4" i	G 1/4" i
Accessories supplied		pendular chuck	pendular chuck	pendular chuck, side handle

Power and free speed at 6 bar operating pressure. Compressed air quality: lubricated.

Accessories

Type	Tapping chuck assy.	Drill chuck key	Integral chuck jaws	Side handles
GE 8 without round wedge	9 369 982	9 369 834	9 369 954	03256-00-5
G 14 with round wedge	9 369 833	9 369 834	9 369 955	03208-97-6



Swivel joint

Variacor 60001-60-6

Further Information see p. 74

Tapping machines

Straight form

- Safety lever start
- Can be used without lubrication
- Integrated silencer
- Ergonomic handle
- Versatile in usage
- Tapping tools for dead end holes upon request



Rotation direction reversed easily by pulling machine



MAS 8

Technical data

Type		MAS 8	MAY 10	MAY 12
Article No.		134 610 108	134 309 028	136 309 016
Start with pressure		lever start	lever start	lever start
Free speed clockwise	rpm	500	450	220
Free speed counter clockwise	rpm	800	930	470
Quick change chuck		yes	yes	yes
Tapping in steel	mm	M 8	M 10	M 12
Tapping in aluminium	mm	M 12	M 13	M 14
Noise level	dB(A)	74	78	78
Air consumption	l/sec	9	11	11
Machine length	mm	240	335	335
Ø machine	mm	40	46	46
Weight without hose	kg	0.98	1.82	1.82
Connection	G	1/4" i	1/4" i	1/4" i
Hose I.D.	mm	8	8	8
Accessories supplied		quick change chuck for tap holder, side handle, pendant		

Power and free speed at 6 bar operating pressure. Compressed air quality: lubricated.

Quick change chuck for tap holder

For tapping air tools	Article No.
MAS 8	65 941 1001
MAY 10	65 961 1001
MAY 12	65 961 1001

Tap holder

Tap holders allow a quick use of different taper sizes

	Ø Shaft taper mm	□ Square drive taper mm	Article No.
M 2	2.8	2.1	65 521 1028
M 3	3.5	2.7	65 527 1035
M 3.5	4.0	3.0	65 530 1040
M 4	4.5	3.4	65 534 1045
M 5 6 8	6.0	4.9	65 549 1060
M 10	7.0	5.5	65 555 1070
M 11	8.0	6.2	65 562 1080
M 12	9.0	7.0	65 570 1090
M 14	11.0	9.0	65 590 1110

Air saw

For sheet steel, aluminium and plastics



SRV 110

- The air saw is ideal for the processing of sheet steel (autobody sheet, pipes out of sheet metal etc.), aluminium and plastics
- High cutting speed
- High performance at low air consumption
- Low noise level
- Anti vibration system patented
- Saw blades of steel
- Safety lever according to EN 792
- Fullfills the European Union guideline 2002 / 44 / EC with the vibration value of 2 m / s²

Technical data

Type		SRV 110
Article No.		29800-27-6
Number of blows	rpm	9 000
Stroke length	mm	8
Air consumption	l / sec	1.5
Noise level	dB(A)	80
Ø machine	mm	41
Machine length	mm	210
Weight without hose	kg	1.15
Hose I. D.	mm	8
Connection		G 1/4" i
Accessories supplied		wrench, 1 set of saw blade

Power and free speed at 6 bar operating pressure.
Compressed air quality: lubricated.

Saw blades | length 96 mm

Range of application	Tooth distance	Teeth per inch	Article No.
ST 37 / V2A and non-ferrous metals up to 1 mm. Suitable for curved cut.	0.8 mm	32	29905-10-6
ST 37 / V2A and non-ferrous metals up to 2 mm. Suitable for curved cut.	1.0 mm	24	29905-11-6
ST 37 / V2A and non-ferrous metals up to 2.5 mm. Wood, plastics, laminated fabrics.	1.8 mm	14	29905-12-6

Chipping hammers

Straight form

- To remove welding cinder and paint as well as for concrete plastering
- Extremely low vibrations level: 2 m/s^2
- Patented vibration system
- Noise level under 80 dB(A)
- Blowing function available on request



SHV 150

Technical data

Type		SHV 150	SHV 150 B
Article No.		35970-00-6	35970-01-6
Valve		lever start	lever start
Number of blows	rpm	9 000	9 000
Frequency	Hz	150	150
Exhaust air		to front	to front
Vibration	m/s^2	2.0	2.0
Noise level	dB(A)	76	76
Air consumption	l/sec	1.5	1.5
Ø machine	mm	40	40
Machine length	mm	210	210
Weight	kg	1.45	1.45
Hose I. D.	mm	6	6
Connection thread		G 1/4" i	G 1/4" i
Accessories supplied		wrench	wrench

Power and number of blows at 6 bar operating pressure. Compressed air quality: lubricated.

Flat chisel

For type		SHV 150, SHV 150 B
Flat chisel, with tungsten tip	100 × 10 mm	39525606
Flat chisel, with tungsten tip	100 × 17 mm	39525616
Flat chisel, with tungsten tip	100 × 36 mm	39525626

Needle scalers

- Versatile use for burring, cleaning, separating slag, trimming of castings, roughening, removing of paint
- Easy change of needles with bayonet joint
- Vibration level $\leq 5 \text{ m/s}^2$
- Patented vibration system
- Low air consumption



GNV 19 | GNV 28



NGV 18

Technical data

Type		GNV 19	GNV 28	NGV 18
Article No.		60000-73-6	60003-89-6	29701-11-6
Valve		lever start	lever start	lever start
Number of blows	rpm	6 600	5 500	8 700
Frequency	Hz	110	91	145
Exhaust air		to front	to front	to front
Vibration	m/s^2	3.7	4.0	3.5
Number of needles		19	28	18
Length of needles	mm	127	140	127
Ø needle	mm	3.2	3.2	3.0
Noise level	dB(A)	98	99	93
Air consumption	l/sec	2.0	2.2	1.6
Ø machine	mm	49	49	40
Machine length	mm	272	290	310
Weight	kg	2.40	3.05	1.95
Hose I. D.	mm	10	10	10
Connection thread		G 1/4" i	G 1/4" i	G 1/4" i
Accessories supplied		needle set	needle set	needle set

Power and number of blows at 6 bar operating pressure. Compressed air quality: lubricated.

Needles for replacement

For Type	GNV 19	GNV 28	NGV 18
Set	9376918 (127 mm)	9376919 (140 mm)	9376917 (178 mm)
Set	9376914 (178 mm)	9376920 (178 mm)	9376913 (127 mm)

Assembly and torque measuring technology
For the complete range of assembly tools
see our website or ask our local partner





The many advantages of MANNESMANN DEMAG impact wrenches:

- Excellent power / weight ratios and very small reaction forces
- Easy and non-tiring to use
- Comfortable to service thanks to their two-part housing
- High power production with an economical air consumption
- For robust use in all branches of industry
- Can be used over a wide range thanks to adjustable impact strength
- Exhaust air through the handle

Hammer mechanism options:

- 1 TWIN hammer mechanism allows two strikes per round on both sides of the drive spindle
- 2 The three jaw system strikes both jaws of the drive spindle simultaneously for an outstanding high power
- 3 One jaw hammer mechanism strike once on one side of the drive spindle for a very powerful impulse

Impact wrenches

Guideline values for torques and pretensioning forces according to DIN 13

Screw quality according to DIN 267

Size	screw width internal mm	screw width external mm	3.6 torque Nm	4.6 torque Nm	4.8 torque Nm	5.6 torque Nm	5.8 torque Nm	6.9 torque Nm	8.8 torque Nm	10.9 torque Nm	12.9 torque Nm
M 4	3	7	0.85	1.10	1.50	1.40	1.90	2.30	2.90	4.10	4.90
M 5	4	9	1.70	2.20	3.00	2.80	3.70	4.50	6.00	8.50	10.00
M 6	5	10	2.90	3.90	5.10	4.80	6.40	7.70	10.00	14.00	17.00
M 8	6	13	7.00	9.30	12.00	12.00	16.00	19.00	25.00	35.00	41.00
M 10	8	17	14.00	19.00	25.00	23.00	31.00	37.00	49.00	69.00	83.00
M 12	10	19	24.00	32.00	43.00	40.00	54.00	65.00	86.00	120.00	145.00
M 14	12	22	39.00	51.00	68.00	64.00	86.00	105.00	135.00	190.00	230.00
M 16	14	24	59.00	79.00	105.00	98.00	130.00	155.00	210.00	295.00	355.00
M 18	14	27	81.00	110.00	145.00	135.00	180.00	215.00	290.00	405.00	485.00
M 20	17	30	115.00	155.00	205.00	190.00	255.00	305.00	410.00	580.00	690.00
M 22	17	32	155.00	205.00	275.00	260.00	345.00	415.00	550.00	780.00	930.00
M 24	19	36	200.00	265.00	350.00	330.00	440.00	530.00	710.00	1 000	1 200
M 27	19	41	295.00	390.00	520.00	490.00	650.00	780.00	1 050	1 500	1 800
M 30	22	46	395.00	530.00	710.00	660.00	880.00	1 050	1 450	2 000	2 400
M 33	24	50	540.00	720.00	960.00	900.00	1 200	1 450	1 900	2 700	3 250
M 36	27	55	690.00	920.00	1 250	1 150	1 550	1 850	2 450	3 450	4 150
M 39	27	60	920.00	1 200	1 600	1 500	2 000	2 400	3 200	4 500	5 400
M 42	32	65	1 100	1 500	1 950	1 850	2 450	2 950	3 950	5 550	6 650
M 45	32	70	1 400	1 850	2 450	2 300	3 100	3 700	4 950	6 950	8 350
M 48	36	75	1 700	2 250	3 000	2 800	3 750	4 450	5 950	8 400	10 100
M 52	36	80	2 150	2 900	3 850	3 600	4 800	5 750	7 650	10 800	12 900
M 56	—	85	2 700	3 600	4 800	4 500	5 950	7 150	9 550	13 400	16 100
M 60	—	90	3 350	4 450	5 950	5 550	7 400	8 900	11 900	16 700	20 000
M 64	—	95	4 000	5 350	7 150	6 700	8 950	10 700	14 300	20 100	24 100
M 68	—	100	4 850	6 500	8 650	8 100	10 800	13 000	17 300	24 300	29 100

The table shows an overview of necessary torques for screws and nuts of all grades.



Impact wrenches

- Type E 10 PS3 with quick-change chuck
- Type E 25 P: long lifetime because the strike mechanism is permanently greased via an oil bath



E 10 P3



E 10 PS3



E 16 P3



E 24 P3

Technical data

Type		E 10 P3	E 10 PS3	E 16 P3	E 18 P3	E 24 P3	E 25 P	E 27 P
Article No.		29501-56-5	29501-57-5	03954-77-4	29915-32-5	29908-31-5	29946-37-6	60053-08-6
For screws up to	mm	M 6 – M 12	M 6 – M 12	M 6 – M 18	M 8 – M 18	M 14 – M 24	M 14 – M 24	M 14 – M 24
Torque max.	Nm	140	80	350	400	950	1 500	1 600
Working range	Nm	30–110	15–60	70–210	80–240	200–570	320–910	320–910
Driv. square end		3/8"	1/4" SWF	1/2"	1/2"	3/4"	3/4"	3/4"
Length	mm	155	165	180	185	214	189	182
Throttle stages		4	4	4	4	4	—	—
Air consumption	m ³ /min	0.28	0.28	0.40	0.68	0.77	0.95	0.90
Weight	kg	1.20	1.25	2.35	2.40	4.15	5.68	5.95
Number of blows	p. min.	2 600	2 600	1 500	1 100	1 000	830	1 000
Free speed	rpm	10 000	10 000	8 000	6 800	5 300	4 800	5 400
Connection		G 1/4" i	G 1/4" i	G 1/4" i	G 1/4" i	G 3/8" i	G 1/2" i	G 1/2" i
Hose I. D.	mm	10	10	10	10	10	13	13
Noise level	dB(A)	72	72	72	85	85	87	94
Hammer mechanism		jaw hammer mechanism	jaw hammer mechanism	jaw hammer mechanism	TWIN hammer mechanism	three jaw hammer mechanism	TWIN hammer mechanism	three jaw hammer mechanism

Power and free speed at 6 bar operating pressure. Compressed air quality: lubricated.

Accessories supplied

E 10 – E 18	Clamp, impact grease, oil bottle
E 24 – E 57	Thread socket, impact grease, oil bottle

Accessories

Swivel joint

1/4" × 1/4" internal / external	60001-60-6
3/8" × 3/8" internal / external	60001-61-6
1/2" × 1/2" internal / external	60001-62-6



Impact wrench with swivel joint



E 31 P



E 36 P2



E 41 F



E 40 P

Technical data

Type		E 31 P	E 33 P	E 36 P2	E 41 F	E 40 P
Article No.		60029-74-6	29946-39-6	60051-65-6	60053-09-6	60010-92-6
For screws up to	mm	M 16 – M 26	M 18 – M 33	M 18 – M 40	M 18 – M 40	M 18 – M 45
Torque max.	Nm	1 900	2 500	3 000	3 185	3 700
Working range	Nm	200–1 450	490–1325	685–1570	600–2060	785–1670
Driv. square end		1"	1"	1"	1"	1"
Length	mm	266	235	223	299	240
Throttle stages		—	—	—	—	—
Air consumption	m ³ /min	1.10	1.10	1.35	1.25	1.35
Weight	kg	5.60	7.27	9.10	9.50	10.85
Number of blows	p. min.	1 150	780	780	750	755
Free speed	rpm	6 800	4 300	3 100	3 300	3 000
Connection		G 1/2" i	G 1/2" i	G 1/2" i	G 1/2" i	G 1/2" i
Hose I. D.	mm	13	13	13	16	13
Noise level	dB(A)	90	92	90	99	90
Hammer mechanism		three jaw hammer mechanism	three jaw hammer mechanism	three jaw hammer mechanism	three jaw hammer mechanism	three jaw hammer mechanism

Power and free speed at 6 bar operating pressure. Compressed air quality: lubricated.



Accessories

For Types E 31 – 57

Throttle control 1/2" i	03024-47-4
Throttle control 3/8" i	60010-93-6



Extended drive spindle E 33 P (150 mm)

Impact wrenches



E 57 F



A 71

Technical data

Type		E 57 F	A 71	A 81
Article No.		60056-38-6	45700-01-6	45800-01-6
For screws up to	mm	M 24 – M 55	M 30 – M 80	M 50 – M 110
Torque max.	Nm	5 900	8 000	24 000
Working range	Nm	1 300–3 200	2 300–5 275	5 400–7 850
Driv. square end		1 1/2"	1 1/2"	2 1/2"
Length	mm	365	448	535
Throttle stages		—	—	—
Air consumption	m ³ /min	1.60	2.80	5.50
Weight	kg	14.55	32.00	67.00
Number of blows	p. min.	650	515	400
Free speed	rpm	3 200	2 300	2 100
Connection		G 1/2" i	G 3/4" i	G 1" i
Hose I. D.	mm	16	19	25
Noise level	dB(A)	90	104	104
Hammer mechanism		three jaw hammer mechanism	three jaw hammer mechanism	three jaw hammer mechanism

Power and free speed at 6 bar operating pressure. Compressed air quality: lubricated.

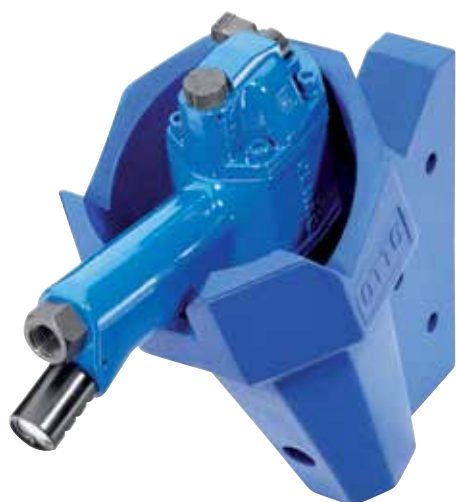

Impact wrench with holster

Holster

for impact and hydropulse wrenches

- Universal and protective
- Tool is always within reach
- Tidy working area

For E 10 – E 18, RRI

60012-17-6

Accessories

For the complete range of accessories
see our website or ask our local partner.



Accessories

Variacor®-swivel joint

For all airtools

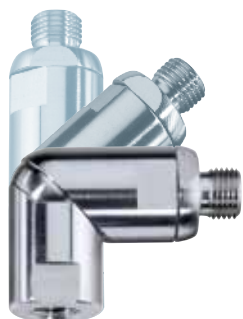

Variable swiveling



Example G 201 HV



More flexibility

The Variacor®-swivel joint can be used with all air tools and inelastic hoses.

System features

- No deviation of the hose means longer lifetime
- Less stress on the workers wrist and muscles means comfortable work
- Efficient: low pressure decrease, connection directly to the tool, hose and tool can be positioned in an optimal way

Dimensions



Connection	A	B	C		D
			internal thread	external thread	
1/4" × 1/4"	24.0	67	G 1/4"	G 1/4"	
3/8" × 3/8"	29.5	82	G 3/8"	G 3/8"	
1/2" × 1/2"	29.5	82	G 1/2"	G 1/2"	
3/4" × 3/4"	46.0	98	G 3/4"	G 3/4"	
1" × 1"	46.0	98	G 1"	G 1"	



Accessories

Variacor®-swivel joint 90° pivoting, 360° turning



Technical data

Connection	Thread	Air flow l/sec	Weight g	Ø internal mm	Article No.
1/4" × 1/4"	internal / external	12	72	7	60001-60-6
3/8" × 3/8"	internal / external	30	126	11	60001-61-6
1/2" × 1/2"	internal / external	30	132	11	60001-62-6
3/4" × 3/4"	internal / external	52	358	16	60001-63-6
1" × 1"	internal / external	52	372	16	60001-64-6

Max. 10 bar air pressure. Temperature range min. – max.: –10 to +70 °C.



Accessories

Filter lubrication units (FLU), pressure reducers, special oil



Service unit and compressed air special oil

Pressure reducer and accessories

Filter lubrication units

- Block-built, two-piece
- Consist of condensate filter with pressure regulator and oil-fog lubricator

		with increased air flow!			
Connection		1/4"	3/8"	1/2"	1"
Article No.		030 290 74	030 291 74	030 292 74	030 293 74
Operat. pressure min. – max.	bar	0.5 – 16	0.5 – 16	0.5 – 16	0.5 – 16
Flow rate max.	m ³ / min	1.50	1.80	3.40	5.00
Width × Height	mm	96 × 203	96 × 203	140 × 273	195 × 273

Pressure reducers

- Block-built
- Manual condensate drain

Connection		1/4"
Article No.		030 280 74
Operating pressure min. – max.	bar	0.5 – 16
Flow rate max.	m ³ / min	2.00
Width × Height	mm	48 × 203

Accessories

Distribution unit	R 3/8"	R 3/8"	R 1/2"
Article No.	9325215	9325216	9325217
Outlets	2	3	3

Double nipple	1/4"	3/8"	1/2"
Article No.	49410-50-6	49410-51-6	49410-52-6

Reducing nipple	1/2" × 3/8"	1" × 3/4"
Article No.	9325210	9325211

Compressed air special oil

- For oil-fog lubrication and FLU
- According to DIN 51 524-2 with viscosity class VG 32 according to ISO 3448
- Viscosity at 40 °C: –32 mm² / s; 32 cSt

Special oil	Bottle 1 litre	Can 5 litre
Article No.	095 055 33	095 085 33

Insight in our production



Our highly motivated workers produce precision parts with CNC machining centres in our modern job shop. This is the basis for best quality and optimized lifetime of our air driven products. Precisely fitting parts are the basis for efficient assembly processes and cost effective repairs.

After machining the parts the next steps are assembly and end control. Testing stands with lubricated or dry air record all relevant data of the machines during a fully automated test run. All tools and motors leave our company in tested quality. The quality management monitors all production processes. This is proven with TÜV-Cert. ISO 9001:2008.



Air chisel hammers

The light ones



Our light chisel hammers:

- Safely to operate thanks to a smaller and lighter construction
- High-capacity
- Easy handling
- Ergonomical construction
- Easy maintenance

Should you need a trustworthy **repair service** please contact us.

The light chisel hammers are perfectly suitable for the fettling of foundry products, for light works in the building industry, for the frame-and-body construction to disconnect flangings or welded joints. Please find the corresponding chisels and special designs at www.MANNESMANN-DEMAG.com.

Due to the sensitive start, the extensive regulation of the impact strength (regulators can be found in "Accessories") and the only slight recoil these chisel hammers in connection with round guide bushings are also especially suitable for light and very light riveting works.

Because of their light weight our light chisel hammers are perfectly suitable for restoration works in high altitudes.



Perfectly suitable for:

- Running-off of liquid metal melt
- Breaking loose and cleaning of:
 - Converters
 - Casting ladles
 - Induction furnaces
 - Cupola furnaces
 - Refractory brick lining work

Air chisel hammers With metal silencers



You work under difficult conditions? You better use the best hammers! The robust design is a perfect quality product and especially for the use in heat and melting areas. Our models with metal silencer are extremely vibration dampened. The installed air cushion provides a protection against wearing from unloaded strokes. It is buffered to a working pressure of up to 9 bar.



Worldwide Sales and services

Berlin	Australia
Bielefeld	Austria
Bochum	Belgium
Bremen	Brazil
Cologne	Canada
Dresden	China
Düsseldorf	Croatia
Erfurt	Czech Republic
Essen	Finland
Freiburg	France
Hagen	Hungary
Hamburg	India
Hannover	Iran
Kiel	Italy
Magdeburg	Luxembourg
Mainz	Netherlands
Mühlheim	Mexico
Munich	Poland
Nuremberg	Portugal
Oberhausen	Slovenia
Potsdam	Slowakia
Rheinfelden	Spain
Saarbrücken	Sweden
Schwerin	Switzerland
Singen	Turkey
Stuttgart	Ukraine
Wiesbaden	United Kingdom
	USA

Colophon

Fotografie:
Blühdorn Werbefotografie +, Stuttgart-Fellbach
MANNESMANN DEMAG
PhotoDisc
Print:
Druckhaus Waiblingen

Printed in Germany, © 2017
All rights reserved. No unauthorised use or copying of the contents, particularly trade marks, drawings of the models, article numbers or photographs. No reprinting and mechanical or digital reproduction, even of excerpts, without the formal permission by MANNESMANN DEMAG.

Technical as well as colour and design alterations, serving the product improvement, are subject to change. Errors and errata excepted.

The complete power spectrum

- Precision industrial tools for metal processing
- Precision industrial tools for flexible automation
- Deburring applications for automation applications
- Percussive tools
- Drilling and cutting systems
- Assembly tools, torque meters
- Air motors
- Customized special solutions

MD chisel hammers and rammers for professionals

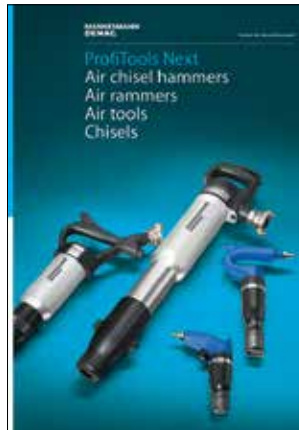

Ask for our special catalogue!

- Experience, quality and service since more than 100 years
- Vibration reduced to the minimum
- We state the exposure time of the hammer (means how long the worker may use the tool ongoingly)
- Outstanding quality of chisels and accessories
- Repair service in our own premises—because service matters

**MANNESMANN
DEMAG**

Druckluftwerkzeuge | Druckluftmotoren

MD Drucklufttechnik GmbH & Co. KG

P. O. box address

Postfach 2001, 71268 Renningen

House address

Rosine-Starz-Strasse 16, 71272 Renningen

Telephone +49 (0) 7159 18093-0

Telefax +49 (0) 7159 18093-100

E-mail info@mannesmann-demag.com

www.MANNESMANN-DEMAG.com

Your MD-Partner
