

Aufnahme nach:
Einsteckende
25 x 75 ISO 1180

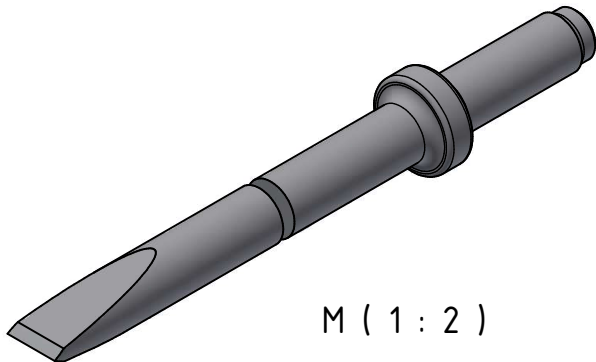
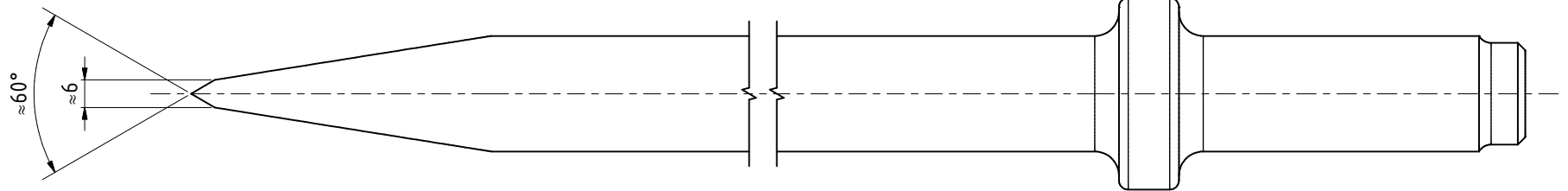
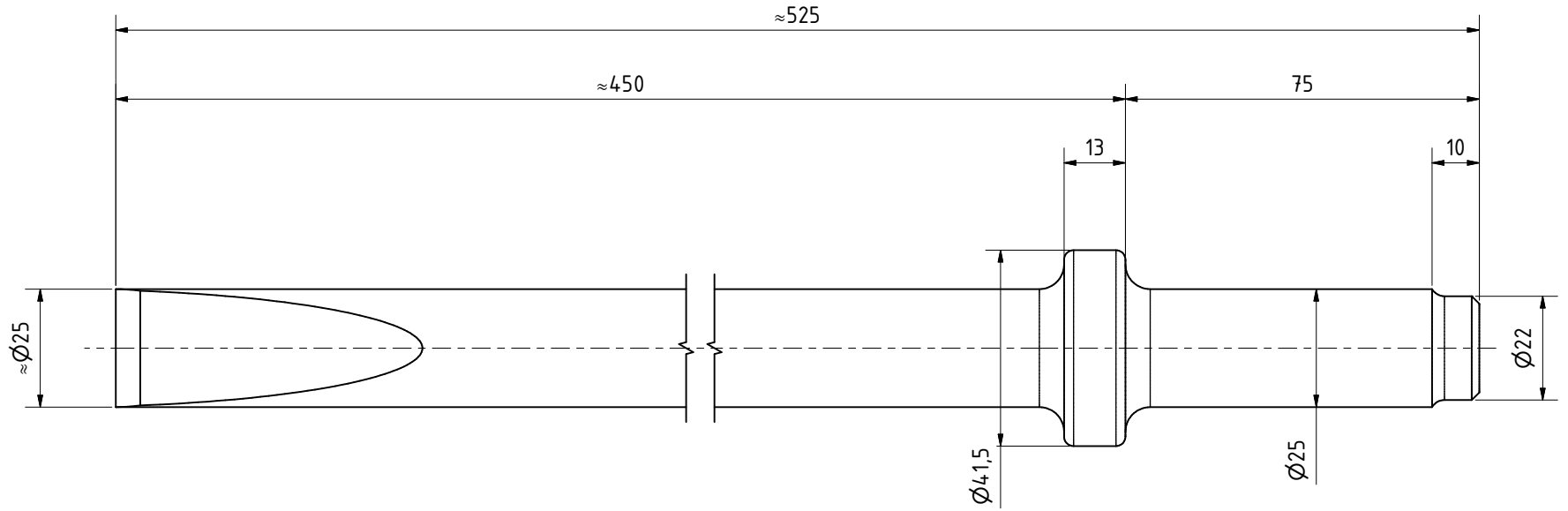
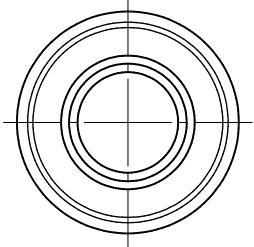

M (1 : 2)

R 25x75 Flach
39509416

MANNESMANN
DEMAG

Änderungsstand: 1

11.09.2023